

SeceuroGlide Compact Installation Instructions

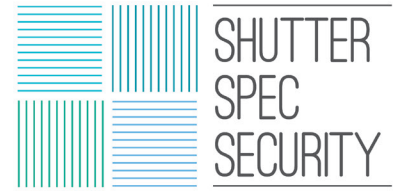

Always check on delivery that the order details are correct and the door is undamaged, especially **before removing any existing doors**.

Sequence of Installation & Contents

01. Pre-Installation and Component Check
02. Installation Options
03. Prepare the Opening
04. Prepare the Guide Rails
05. Fix Guide Rails & Axle Assembly
06. Fit Emergency Overrides
07. Curtain Adjustment (reducing height/making repairs)
08. Install the Curtain in the Guides, Attach to Axle & Fit Stops
09. Curtain Locking and Setting Motor Limit Switches
10. Commissioning

01. PRE-INSTALLATION AND COMPONENT CHECK

Check:

- i. Delivery note
- ii. Order sheet
- iii. Door dimensions / colour
- iv. Opening dimensions / clearances
- v. Components
- vi. Check for any damage to the guide rails or the outside roll of the curtain

Do not proceed further with the installation unless you are sure that the door is the correct size, and all components are present.

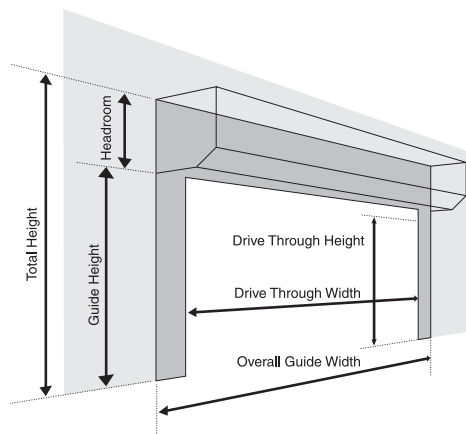

WIDTHS

Manufacturing Width = Over Guide Width
 Drive Through Width = Over Guide Width less 120mm for 60mm guides

HEIGHTS

Manufacturing Height = Guide Height
 Total Height = Guide Height + End Plate
 Headroom/End Plate up to 2.3m Guide Height = 205mm
 Drive Through Height = Guide Height less 50mm

01. 90° Fascia
02. Motor (fitted into axle)
03. 60mm Octagonal Axle
04. 4 Pairs Compact Locking Collars (fitted on axle)
05. Axle Cap (fitted into axle)
06. R/H End Plate
07. 4 No. Compact Locking Springs And Attachment Brackets *
(and 8 hinge pins)
08. 8 No. Retention Clips *
09. L/H End Plate
10. Guide Terminals (fitted to end plate)
11. Optional 45° Lid
12. Guide Rails (UPH 140)
13. Brush Insert (fitted to guide)
14. Curtain
15. End Locks (fitted to curtain)
16. Bottom Slat (fitted to curtain)
17. Rubber Seal (fitted to bottom slat)
18. Override Eye * (not supplied with external fit Compacts)
19. 6 No. M8 X 21mm Penny Washers *
20. 2 No. Stop Blocks *
21. 2 No. M6 X 30mm Coach Bolts * (for fixing stop blocks)
22. 2 No. M6 Nyloc Nuts * (for fixing stop blocks)
23. 10 No. 4mm X 8mm Rivets * (for securing endlocks)
24. 3 No. Cable Clips *
25. Crank Handle Clip *
26. Brush Strip For Fascia *
27. Crank Handle (removable 45° crank handle supplied with external fit Compacts)

*Supplied in Accessory Pack

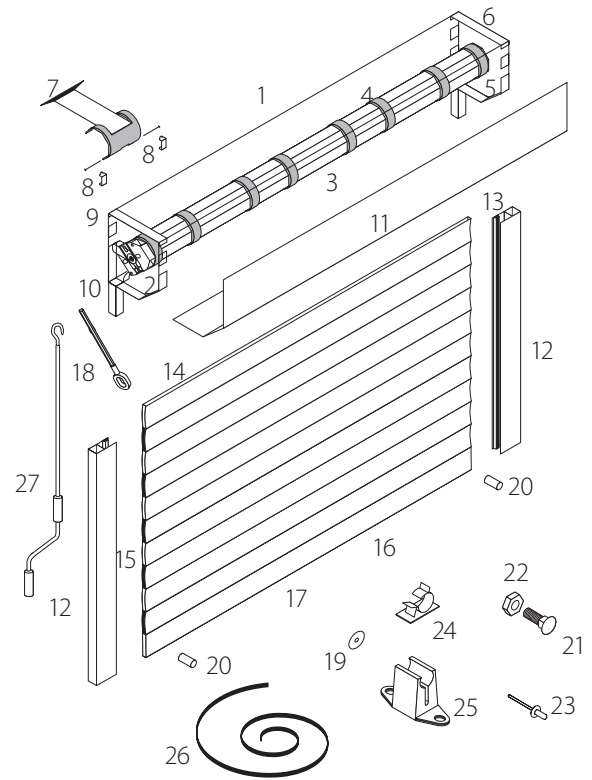

Recommended Fixings (not supplied)
 12 x 1" Self Tapping Screws for Steel
 12 x 2 1/2" Countersunk Screws for
 Masonry and Wood

Axle, end plates, 90 degree fascia (and optional 45 degree lid) are supplied pre-assembled. Guides, crank handle and if applicable external override kit will be wrapped together in one bubble wrapped parcel and strapped together.

The curtain axle/fascia assembly are all individually packed. A separate accessories box is packed with the installation and end user instructions, the attachment/locking arms, the accessory pack and a box containing the electrical items.

02. INSTALLATION OPTIONS

External Fit

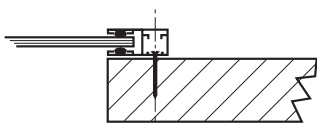

Internal Face Fit

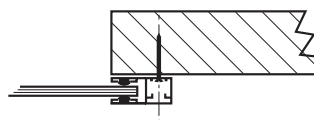

Reveal Fit

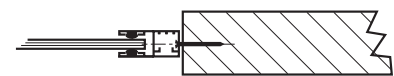

Undersize Face Fit

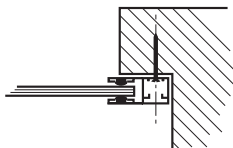

Fitted to existing or New Timber Frame

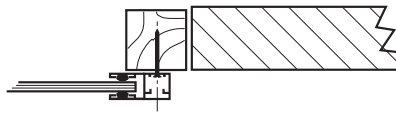

Combination of Face and Reveal Fit

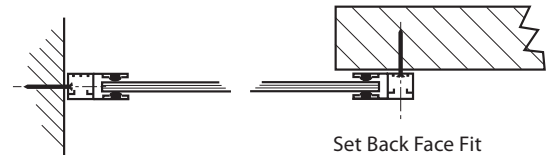

03. PREPARE THE OPENING

Check:

- i. Structure is sound/even & can carry the weight of the door
- ii. No obstacles in fitting footprint eg. no sharp objects, pipes, cables, bumps etc. sticking out from the pillars, lintel or header to twist the guides, distort the fascia or catch on the curtain
- iii. Floor is flat/level
If necessary install a sub-frame to ensure secure, flush and level fixing (Recommended minimum 70 X 70 PAR).

04. PREPARE THE GUIDE RAILS

If the guides require cutting down refer to the 'Widths and Heights' information in Section 1. If face fixing where possible set the guide height at least 50mm above the structural opening height to maximise drive through height.

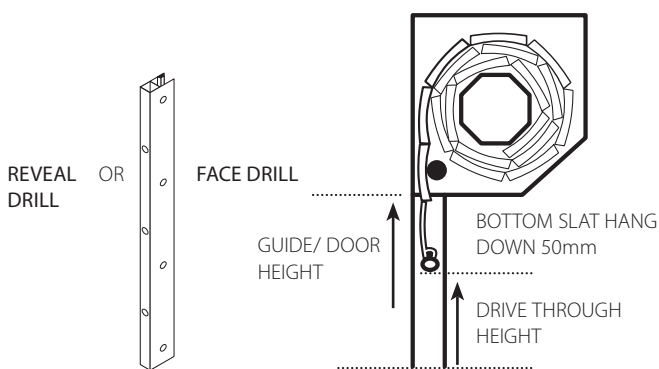

- i. Position guides
- ii. Drill guide fixing holes (min 4) 7mm pilot hole 13mm outer hole, avoid mortar joints and edges of bricks etc.

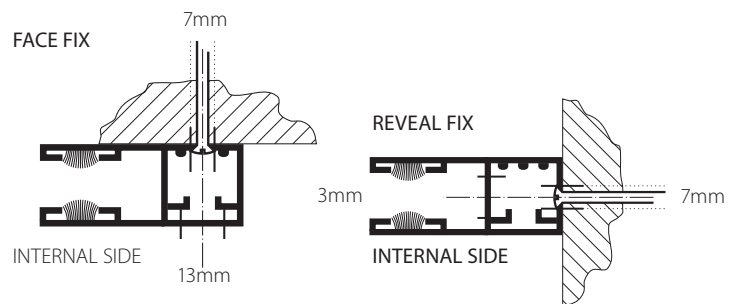

N.B. Guides are handed. If cutting guides cut excess length from bottom of guide.

05. FIX GUIDE RAILS & AXLE ASSEMBLY

N.B. Before positioning check that there are no sharp objects or bumps sticking out from the pillars, lintel or header to twist the guides or distort the fascia.

- i. Slot end plate lugs into guides (see **Drawing A**) remembering the guides are handed (check guide terminals are in place, see **Drawing B**)
- ii. Position guides and fascia against opening
- iii. Hold or prop securely the assembly in position
- iv. Drill fixing holes (min 4 in guides and 2 in each end plate)
- v. Fix guides/end plates with minimum No. 12 x 21/2" countersunk screws (and plugs) to masonry/timber or 12 x 1" self tapping screws to steel. Fix fascia every metre with minimum 12 x 1" screws. Penny washers supplied must be used to spread fixing load on end plates and fascia
- vi. Stick brush strip to inside bottom edge of 90° fascia (optional see **Drawing B**)

N.B. Extreme care should be taken while manoeuvring the door into place to avoid the possibility of snapping the end plate lugs. It is imperative that fixings are put through the end plates into the wall as the aluminium lugs are not designed to carry the weight of the door.

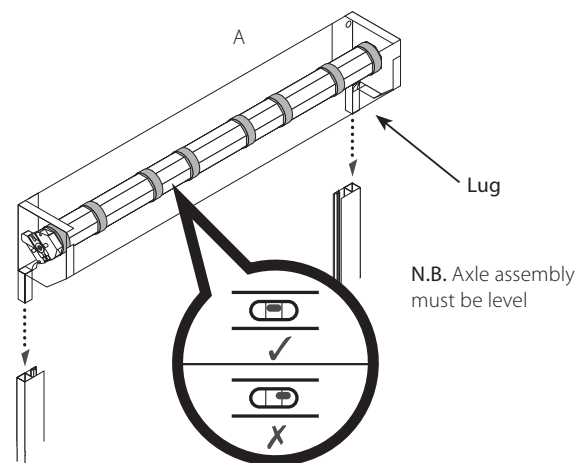

Check:

- i. Back faces of guides and end plates are flush and untwisted (see **Drawing C**)
- ii. Guides are vertical/parallel/same height, this is essential for the bottom slat transmitter (if fitted) to function correctly.
- iii. Axle cap is butting up against the end plate and held in place with at least 2 rivets (see **Drawing B**)
- iv. Collars are correct way around (see **Drawing D**)
- v. Secure Motor Power Lead with Cable Clips so that it is tight against the end plate – see **Drawing E**. You must ensure that you allow for a drip loop in the motor cable to prevent water from running down the cable and into the motor. Spare cable ties can be attached to the motor cable to act as drip loop to prevent water entering the motor.

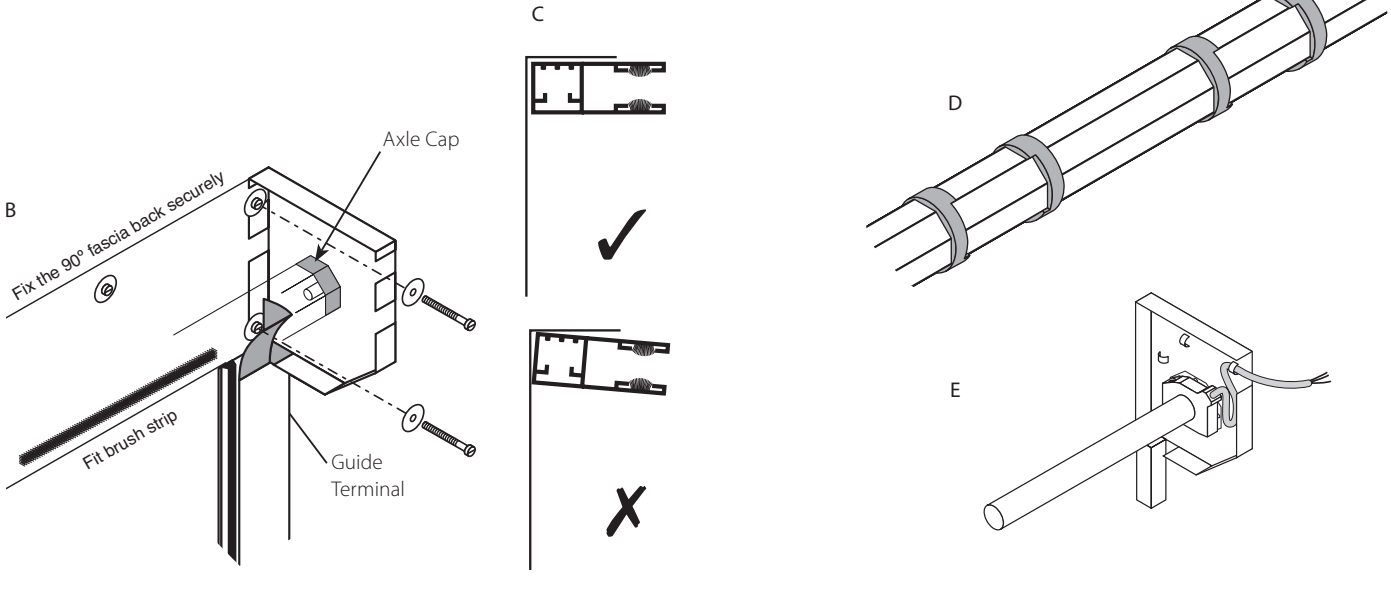

06. FITTING EMERGENCY OVERRIDES

Possible Override Exit Options

N.B. The factory assembled options 1 & 2 are recommended

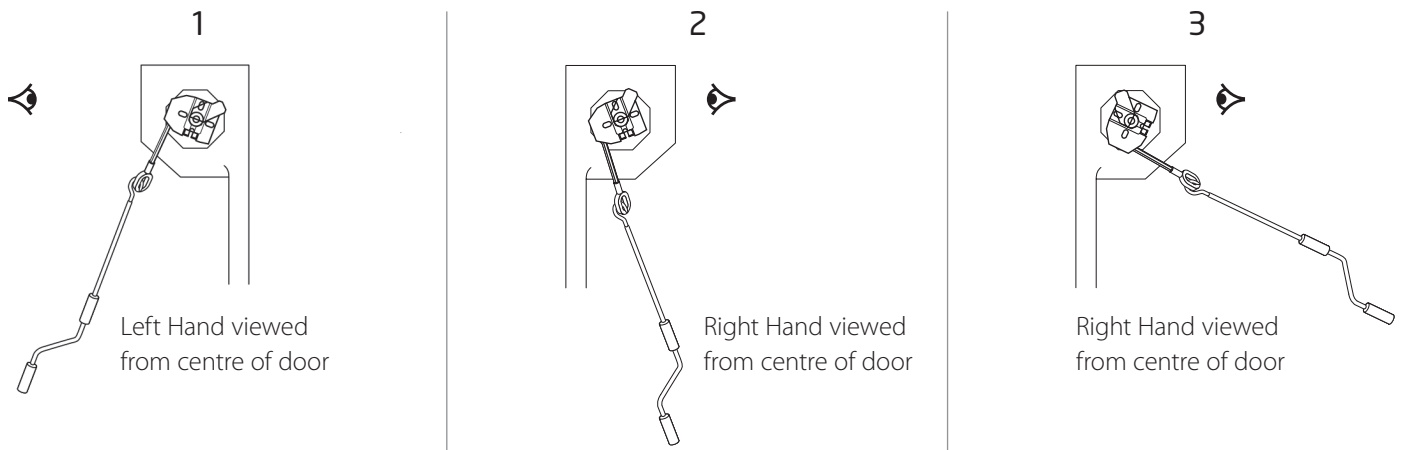

A) Standard Manual Override

Standard Manual Override Internal Fitting
(see **Drawing A**):

- i. Drill hole for override eye through end plate flange
- ii. Insert override eye in hole in motor adjacent to limit adjusters
- iii. Insert and tighten the holding screw and washer from above
- iv. Hook crank handle in eye
- v. Secure clear of shutter with crank handle clip

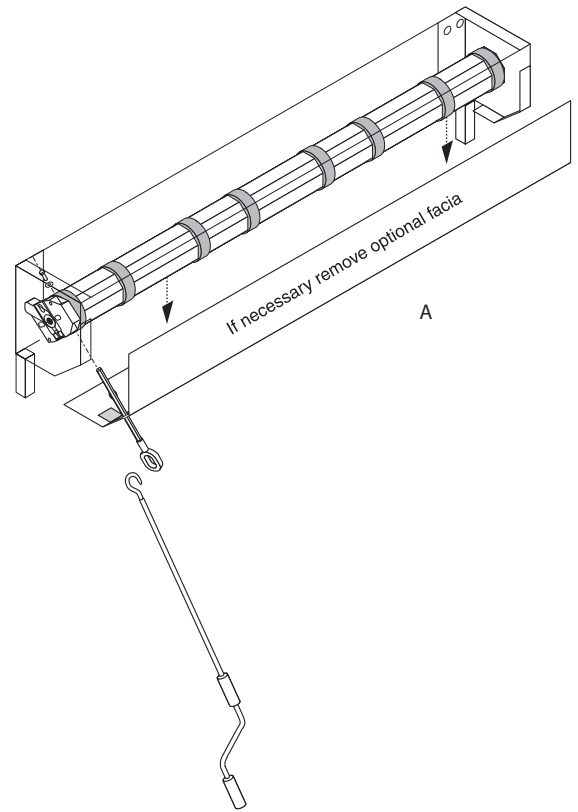

B) Optional Low Level External Override

N.B. It is suggested that the override exits as per diagram 2 on the previous page.
Please note more detailed installation instructions are supplied in the override kit.

- i. Drill hole for override eye through end plate flange
- ii. Insert hexagonal bar through hole in motor adjacent to limit adjusters (see **Drawing B**)
- iii. Mark position for hole through wall adjacent to guide rail at bottom end of crank (see **Drawing C**). Crank can exit at 90° if door tight to return wall (see **Drawing D**). Length of shaft can be shortened to adjust operating height.
- iv. Drill 22 mm hole through the wall (see **Drawing C**)
- v. Secure universal joint bracket to wall
- vi. Insert tube (cut to length) and fix plate to wall (see **Drawing E**)

N.B. Fixings not supplied.

Externally Fitted Compact Roller Garage Door

The crank handle is not permanently attached but is only inserted as required (also see Section 10)

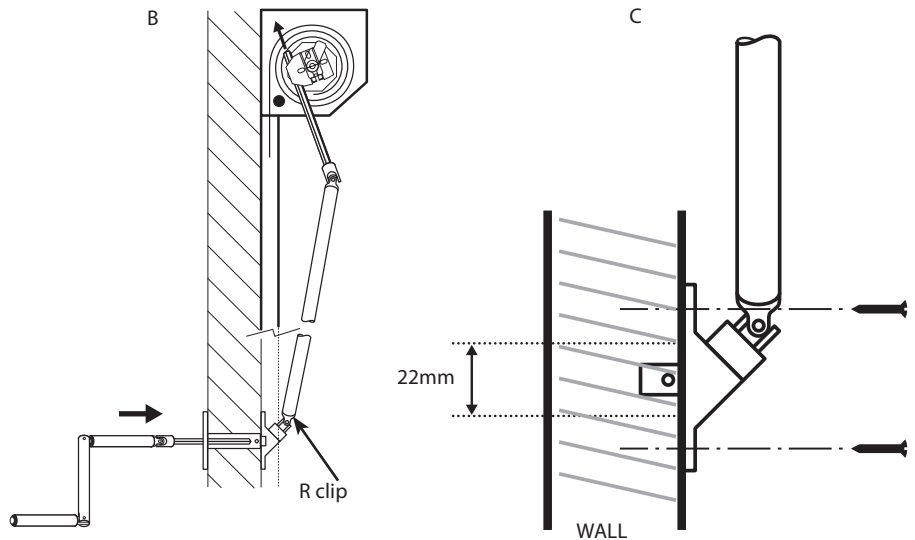

To operate the Low level override from inside the garage remove the R clip and then wind the handle.

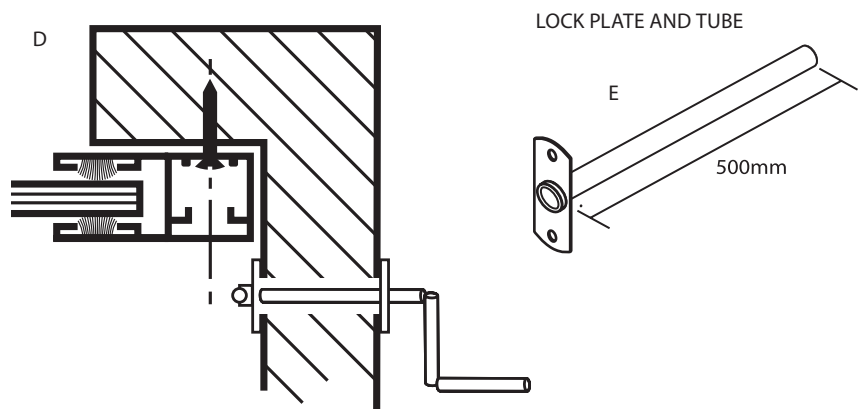

07. CURTAIN ADJUSTMENT (REDUCING HEIGHT/MAKING REPAIRS)

If the door needs to be reduced in width it will need returning to the supplier.

The curtain needs to be the correct height for the door to lock properly (if too tall remove slat(s) – If too short notify supplier). Check you have the correct number of slats in the curtain for the guide height (particularly if you have shortened the guide height) and adjust the curtain accordingly.

Snip ear off endlock to release slats

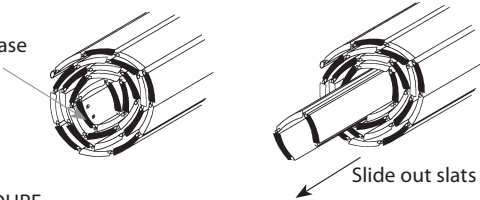

REPAIR PROCEDURE

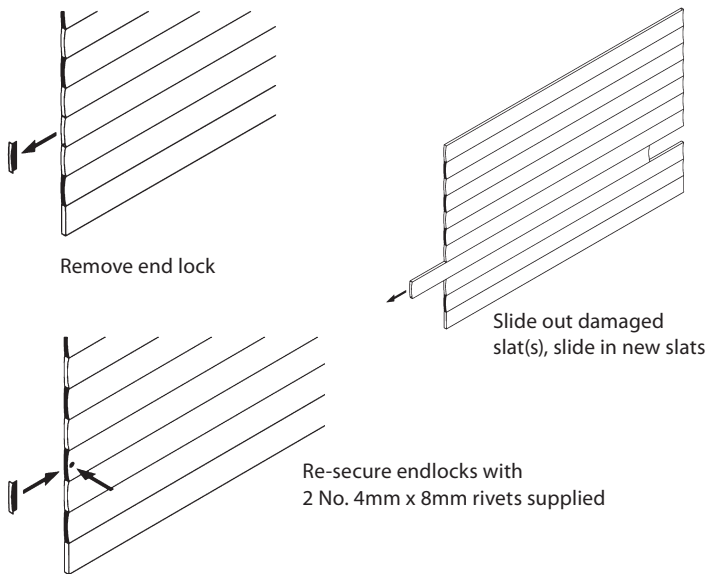

Remove slat by carefully snipping ear off end lock before sliding out slat. Preferably take slats off from the top of the curtain to save having to remove and refit bottom slat. Either roll curtain out on a flat and protected surface such as the bubble wrap and/or cardboard packaging in which the curtain is delivered, or do as below.

08. INSTALL THE CURTAIN IN THE GUIDES, ATTACH TO AXLE & FIT STOPS

- Check that there are at least 4 pairs of compact locking collars on the axle and that each pair of collars has the cut-out towards the centre and line up with other pairs of collars along the axle (see **Drawing A**). One pair must be approx. 150mm in from each end of the axle and the remaining pairs evenly spaced.
- Lift coiled curtain up level with axle and feed bottom of curtain into guide (see **Drawing B**)
- Slowly unroll curtain and gently lower onto a tool box or block (see **Drawing B**)

N.B. Do not allow the curtain to free fall over the axle as this will result in damage to the curtain.

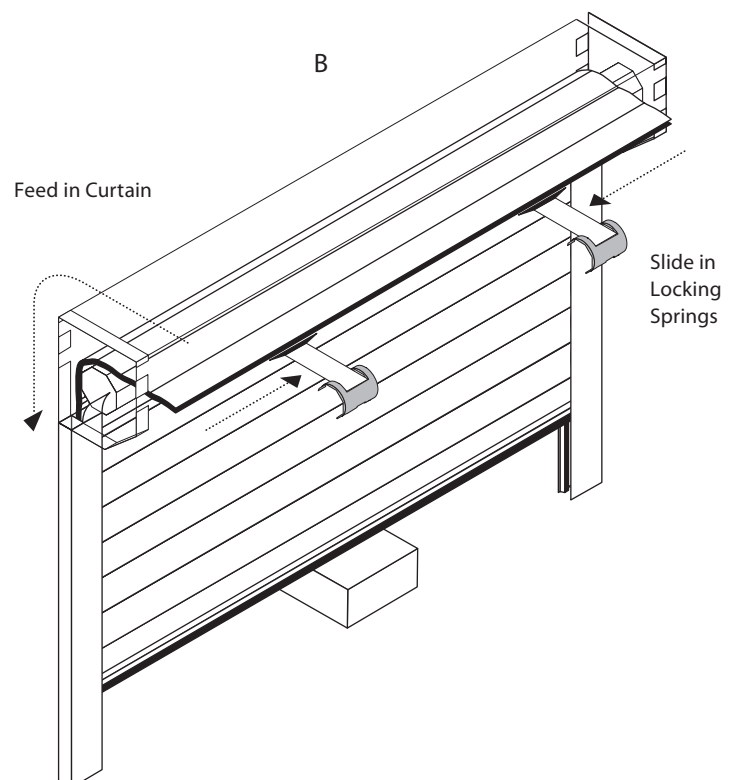
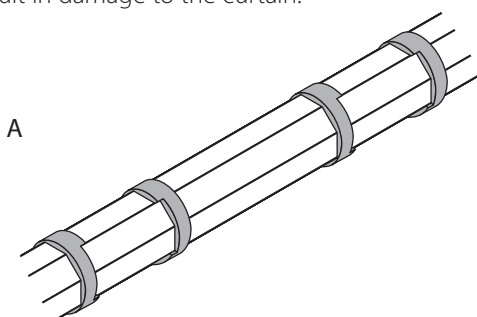

08. INSTALL THE CURTAIN IN THE GUIDES, ATTACH TO AXLE & FIT STOPS (CONTINUED)

- iv. Slide the locking springs with semi-circular attachment bracket onto the top slat. Rotate the axle with the manual override until the attachment holes in the collars are accessible.

Use the special attachment pins as supplied to attach the semi-circular attachment bracket between the collars.

N.B. You must use the second hole. Ensure that the pin is fully engaged in the attachment bracket (it should click into place) to prevent product failure (see **Drawing C**).

- v. Fit small retention clips into the cut-outs in the axle to stop the locking assemblies moving along the axle. The clips do not have to be tight up against the collar. (see **Drawing D**)

- vi. Use override to raise door sufficiently to remove toolbox/block. Ensure that the semi-circular curtain attachment bracket coils up flush with the collars (see **Drawing E**). Leave door in partially open position.

- vii. Drill 8mm hole close to edge of bottom slat and fit stops (preferably to the outside, see **Drawing F**). It is essential the stops are fitted for health and safety reasons

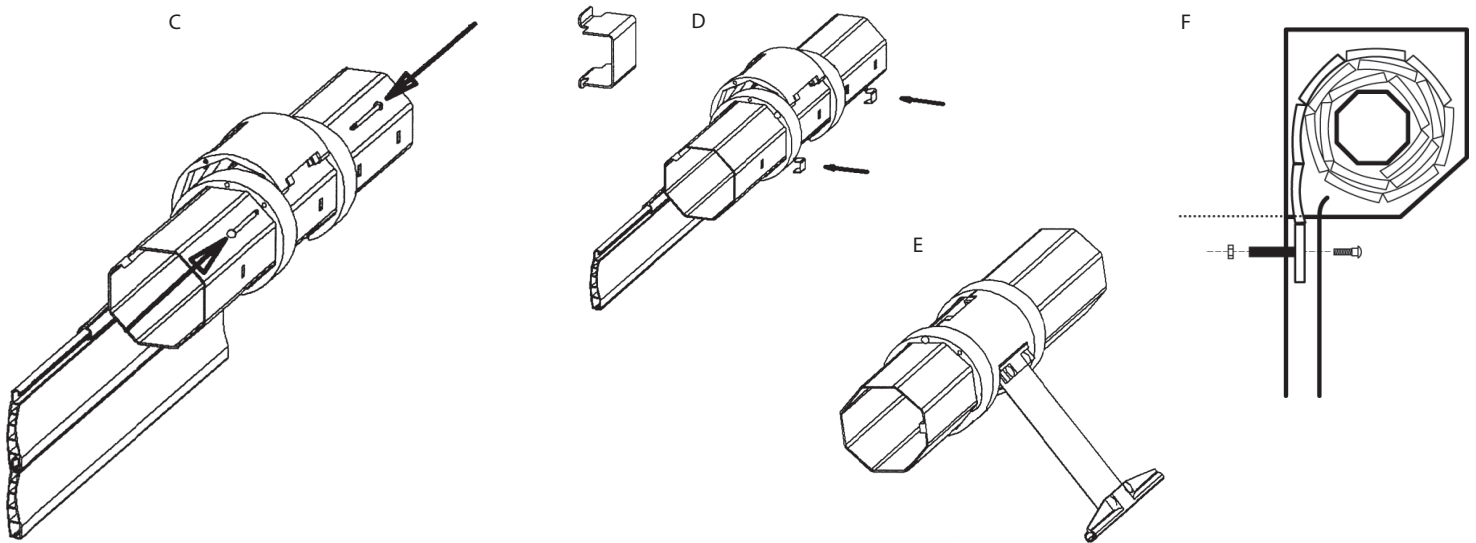

09. CURTAIN LOCKING & SETTING MOTOR LIMIT SWITCHES

The roller garage doors are manufactured with the curtain height to suit the length of guide supplied.

The door will not lock down properly if the curtain is either too tall or too short – see **Drawing A & B**.

For Classic and Excel, ensure the locking blocks are in place – refer to locking procedure **Section 7**.

We recommend using a test lead when carrying out this operation. Failure to do this could result in damage or injury.

- i. Connect the motor cable to a test lead.
- ii. Ensure you follow the correct instructions for the correct motor.
- iii. Drive the axle to the fully closed position.
- iv. Attach the curtain to the axle and fine tune the closing limit. (follow instruction if anti-fall back spring is being used) – see **Drawing B**.
- v. Drive the curtain to the open position and set the top limit to the fully open position with the bottom slat fully in the in the guide – see **Drawing D**.
- vi. Run the door to test top and bottom limit and connect the motor cable to the receiver unit.

Open/up limit setting

- i. Send the door up with the test lead to open/up position and stop (50mm of curtain should still be in guide. Stops should be 10mm below fascia – see **Drawing D**).
- ii. Press and release the open/up limit switch.

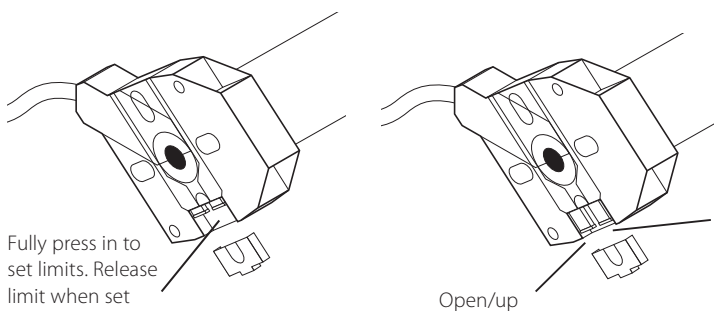

N.B. Always replace the yellow limit switch cover cap once limits are set.

Somfy motor drive only

- i. Remove the yellow cap and press both buttons inwards.
- ii. Drive the door to the down position.
- iii. If the axle contains an anti-fall back spring then count the amount of turn so it matches the amount written on the sticker on the axle.
- iv. If no springs are present then set the down limit when the axle stops.

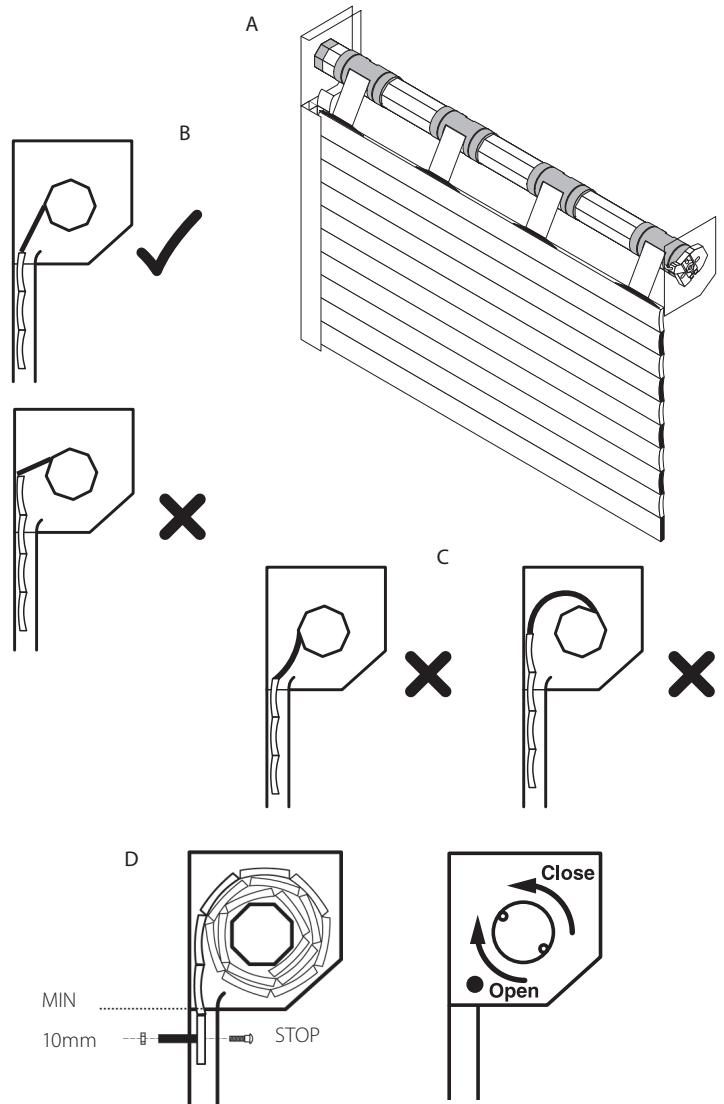

SeceuroDrive motor only

- i. Using the limit adjusting tool, drive the axle to the fully closed position.
- ii. If axle contains an anti-fall back spring then you must count the amount of turns.
- iii. Look at the number of turns required on the sticker and then add this amount of turns to the downwards action.
- iv. If no springs are present then set the down limit when the axle stops.

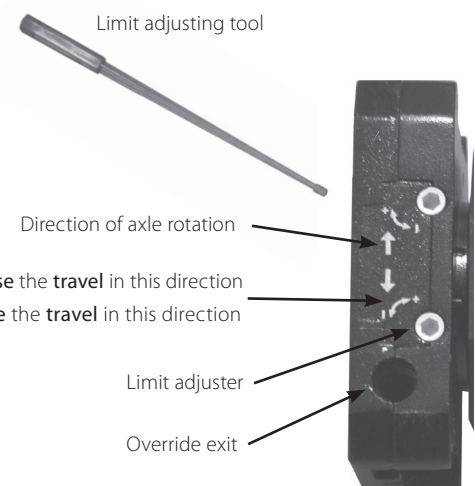

Internal Fitting

Fit optional 45 degree lid. A slot may have to be cut into the lid to pass over the override eye.

Final Checks

- i. Remove any protective plastic coverings.
- ii. Wipe curtain & guides with damp cloth.
- iii. Touch-up any small scratches.
- iv. Check all electrical & operating equipment is installed and functioning correctly (especially the safety edge) and complete CE marking label and paperwork.
- v. Check direction handle needs winding to open door and fit appropriate label supplied to crank handle.
- vi. If the door is fitted externally apply a bead of silicone around the box edge to prevent water ingress.
- vii. Attach stops to bottom slat 230mm in from the outer edges of the bottom slat.

N.B. Check the front of the curtain to make sure that it is not rubbing on the fascia etc.

The manual override will not function after the door is operated by remote control, until the power to the motor has 'timed out'.

This will take a few moments to occur.

If you wish to demonstrate the manual override immediately after opening the door press either the stop button on the handset or simulate a power cut by switching off the power to the Control Unit.

If a low level external override is fitted or the door is fitted externally remind customers to keep the override handle in a convenient place (not in the garage if no other way in!)

Upon completion it is your responsibility to train the customer how to operate the door correctly and safely and provide them with the operating and maintenance instructions supplied.

