

SHUTTER INSTALLATION INSTRUCTIONS



All rights reserved; no part of this publication may be reproduced, stored in a retrieval system, or transmitted in any form or by any means, electronic, mechanical, photocopying, recording or otherwise without the written permission of SWS UK.

1 Contents

GENERAL		
2	Key to Symbols/Meanings	4
3	Warranty / Life Cycles	5
4	General Safety Advice	6
	4.1 General information	6
	4.2 Repairing / Dismantling	7
5	Tools/Fixings required	8
6	Preparation for the Installation	9
INSTALLATION INSTRUCTIONS		
7	Built-On Shutters	10
	7.1 Manual Belt Operation	10–15
	7.2 Rod Crank Operation	16–19
	7.3 Spring Loaded Operation	20–24
	7.4 Electric Operation	25–29
8	Built-In Shutters	30
	8.1 Rod Crank Operation	32–33
	8.2 Spring Loaded Operation	34–36
	8.3 Electric Operation	37–39
9	Insurance/Police Approved Built-On Security Shutter	40–44
10	Traditional Commercial Shutters	45
	10.1 Spring Loaded Operation	46–49
	10.2 Electric Operation	50–54
APPENDIX		
11	Electric Control Options	55–66
	11.1 Connecting hold to run switches	55–56
	11.2 Connecting the remote control	57–65
	11.3 Alternative control methods	66
12	Setting Motor Limits	67
13	Anti-fall Back Devices	68–71
	13.1 Anti-drop Brakes	68–69
	13.2 Anti-fall Back Springs (Electric Operation)	70
	13.3 Anti-fall Back Springs (Spring Loaded Operation)	70–71
14	Sloping Bottom Slats	72
15	Removable Guide Rails	73
16	Technical Details	75

2 Key to Symbols/ Meanings:



WARNING!
Risk of personal injury!

This is an important piece of safety advice which must be observed to avoid a risk of personal injury!



ATTENTION
Risk of material damage!

This is an important piece of safety advice to avoid damaging the product you are installing!



Operational check:

At this stage of the installation a component of the door, the operation of the door or the operator can be tested. This is very important as it can immediately identify an error which could take time to discover at a later stage.

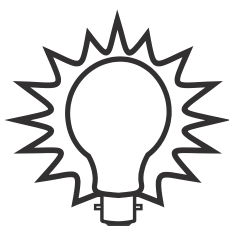

Advice / Tip

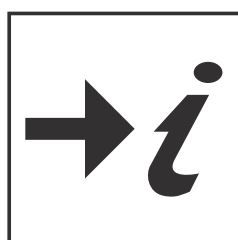

Reference to further product information

Here a reference is made to another set of instructions which need to be used for installation of a particular component.

3 Warranty / Life Cycles

The warranty for this product is only granted if:

- **The installation is carried out by a competent installation engineer following these instructions.**
- **Only original parts are used.**
- **No additional objects are attached to the door.**
- **Regular maintenance checks are performed.**

For further details on the products warranties please refer to the products price list and our terms and conditions which are available upon on request.

To comply with the Construction Products Directive all products have been durability tested for a minimum of 11,000 cycles.

4 General Safety Advice

4.1 General Information



This document is intended for a qualified, trained installation engineer and should not be given to the owner of the door but should be kept by the installer.

To comply with the Construction Products Directive and the Machinery Directive the product must be installed in accordance with these instructions.

Please read all safety advice and relevant instructions carefully.

These installation instructions are intended for qualified and trained installation engineers. Installation, initial operation, servicing, repairs and dismantling of this product should only be carried out by a qualified and trained installation engineer.

When installing an electrically operated product ensure the mains power supply to the product is disconnected before any electrical connections are attempted.

Before operating a shutter you must always ensure that there are no persons or objects in the opening before and during the opening.

The shutter should only be operated when in view.

Upon completion of the installation the owner of the shutter must be trained how to operate the product safely paying special attention to the following points:

- **The shutter should only be operated when in view**
- **The operator should ensure there are no objects or persons in the opening before and during operation.**
- **The end user must read and follow the advice given in the operating and maintenance instructions.**
- **In the event of a malfunction the end user should follow the advice given in the operating and maintenance instructions and if applicable contact the installer.**

During the installation of the shutter you should follow safe working practices. Further advice is available from the Health and Safety Executive (HSE).

4.2 Repairing/ Dismantling / Maintenance

Always isolate the mains power before attempting any maintenance, repairs or dismantling. If you need to use the optional remote control during any maintenance, repairs or dismantling procedure you must engage the commissioning mode.

Before attempting to repair or dismantle a shutter you should check for the presence of any safety devices, for example:

- **Anti-fall back spring**
- **Anti-drop brake**
- **Bottom slat safety edge**
- **Safety photo cell**

Before attempting to remove an axle assembly which contains a spring you must release the tension in the spring.

When repairing or dismantling a shutter you should keep the opening and the surrounding area clear to prevent risk of injury to yourself and others.

When repairing or dismantling a shutter you should follow safe working practices. Further advice is available from the Health and Safety Executive (HSE).

Maintenance check list:

- **Curtain free running and clean**
- **All end locks are correctly and securely located in the curtain**
- **No debris in the guide rails**
- **Guide rails and end plates are securely fastened to the wall (check also the fascia if fitted)**
- **If applicable all axle collars and locking springs are in the correct original position**
- **Check action of applicable locking devices to ensure they are engaging correctly**
- **If applicable motor cable is correctly retained, has not been damaged or in danger of being damaged**
- **If a remote control has been supplied check the functionality of the safety devices**
- **If required view the service counter on the remote control**
- **If an anti-fall back spring is fitted check that the spring is under tension when the curtain is in the fully closed position. You should not be able to turn the spring shaft located in the u-cup.**
- **Check the operation of the manual override.**

Recommended service period

The recommended service period for a shutter which will operate on average two cycles per day is once every 12 months. If the shutter will perform a greater number of cycles per day the service period should be shortened accordingly. One cycle is a full open and close sequence.

5 Tools/ Fixings Required

This list of tools and fixings is a minimum guide, to be adapted for each installation.

- **Drill with pneumatic/hammer action to take the drill bits used below**
- **10mm & 22mm masonry bits up to 400mm long (or wall thickness)**
- **3, 4.2, 5, 10 & 13mm metal drill bits**
- **Countersunk posidrive type fixings or similar, with appropriate masonry drill bits and rawl plugs for guide rails and shutter box**
- **Guide rails and end plates require at least 2 1/2 inch 10s or 12s twin threaded screws with brown rawl plugs**
- **To secure the shutter box to the wall use at least 1 1/2 inch 8s screws with red plugs. A 250mm long masonry drill bit will be required**
- **Screw drivers and wire strippers**
- **4mm & 6mm Allen keys**
- **Pliers**
- **Tin Snips**
- **Metal files - round, half round and flat**
- **Spirit level**
- **Straight edge (square)**
- **Plastic hammer**
- **Tape measure**
- **Marker pen**
- **3 core and 4 core cable**
- **Junction box**
- **3 amp plug**
- **Surface trunking**
- **Motor test lead (YEC38400)**
- **Hacksaw**
- **Pop riveter with 4mm brown or white rivets**
- **Dust sheets**
- **Step ladders**
- **Workmate bench (optional)**
- **Silicone gun with brown, white or clear silicone**
- **If the fitting surface is not flat or there is a projecting door handle, painted timber may be required to form a sub frame. Alternatively 20/50 x 50mm aluminium packers or pieces of guide rail may be used**
- **If the shutter box is to fit up into a soffit, a circular saw or jigsaw will be needed to cut the soffit board.**

6 Preparation for the Installation

The structure of the opening must be adequate to take the weight of the door and suitable to take the appropriate fixings.



RISK OF MATERIAL DAMAGE Check that the opening is ready for installation. Surfaces should be flat and vertical to guarantee a parallel alignment of the guide rails. It is important that you check that the lintel does not bow inwards or have any projections that may catch on the curtain or could push the box back towards the curtain. If in doubt pack the guides and box out by at least 10mm.

Before you begin installing the shutter you should check that the shutter will not foul on any opening doors or windows or projecting door handles.

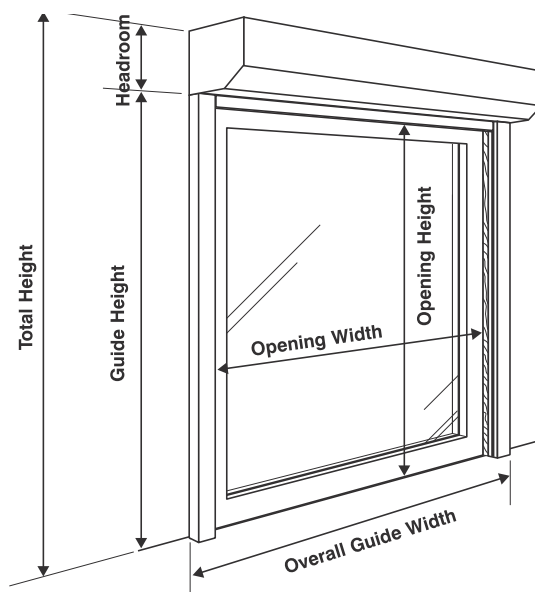

RISK OF MATERIAL DAMAGE Check the dimensions of the opening to ensure that the product supplied is the correct size to suit the opening. This must be done before removing any existing products and before you begin installation of the shutter.

To avoid damages to the box and the curtain unpack the components very carefully. We recommend using the packaging supplied as a protective mat.

Check the packages you have received to ensure you have received all the parts you require and they are in a satisfactory condition before you begin installation of the shutter.

7 Built-On-Shutters

7.1 Manual Belt Operation Parts List

General Parts

- Assembled shutter box (1 per shutter)
- Pair of guide rails (1 pair per shutter)
- Assembled curtain (1 per shutter)
- Installation instructions
- Operating & Maintenance instructions

Operation Specific Parts

- Swivel belt winder / Geared belt winder (1 per shutter)
- Handle for geared belt winder (1 per shutter if geared belt winder required)
- Large belt roller (1 per shutter if shutter fitted externally)
- Belt tube (1 per shutter if shutter fitted externally)

Accessories are packed in a separate box.

If applicable angle & packer are usually packed with the guide rails.

Guide to correct guide rail orientation

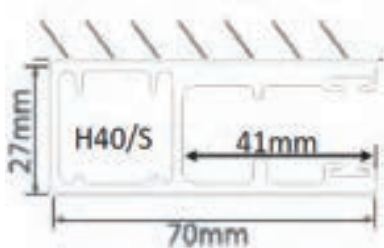

Certain guide rails have an internal and external face, due to their extrusion profile. These guide rails must be installed the correct way round. Please check the guide rails you have been supplied before you begin installing the shutter.

7.1 Manual Belt Operation Installation Instructions

Before you begin installing the shutter please ensure you have read pages 4–9.

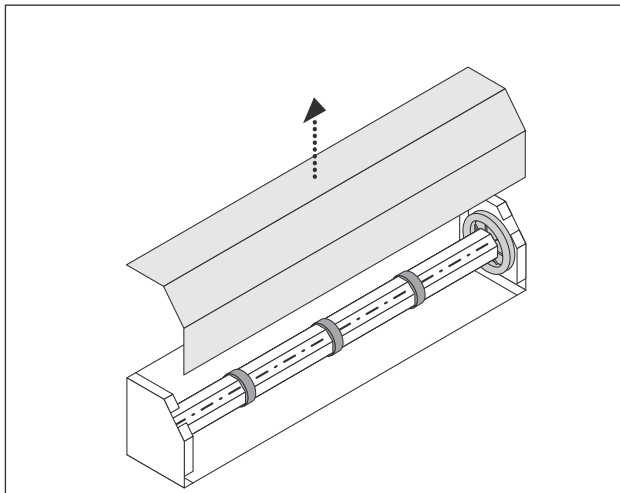

1 Remove lid from box

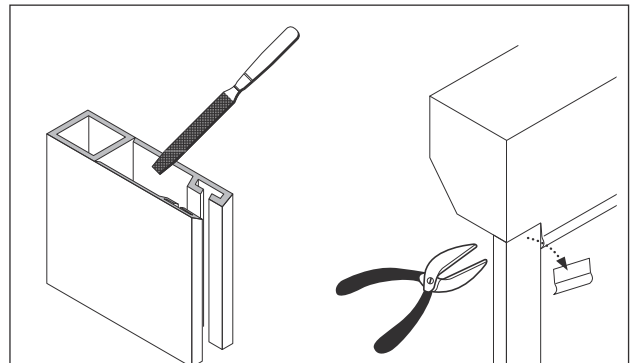

2 File the top of the guides at an angle to create the optimum lead in for the curtain. Guide insert should also be trimmed to suit the filed guide top and securely crimped in place. If the shutter is being face fitted remove the lip from the box back which overlaps the guide rails.

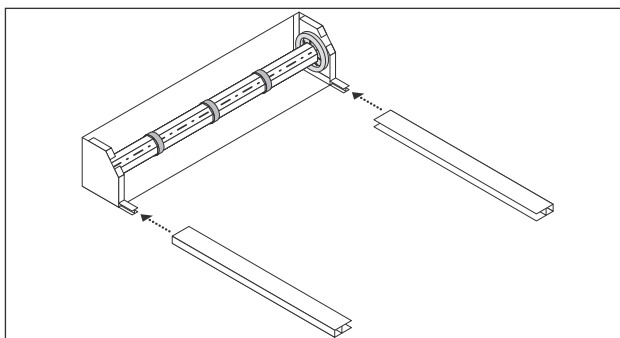

3 Carefully locate the guide rails fully onto the box lugs ensuring that on face fit guides the 13mm holes are on the outside. When moving the shutter as a complete unit you should minimise the movement of the guide rails to prevent the locating lugs from being snapped off the shutter box. If the shutter is too large to be lifted up as a complete unit you should offer up, locate and fix the individual guide rails then the shutter box.

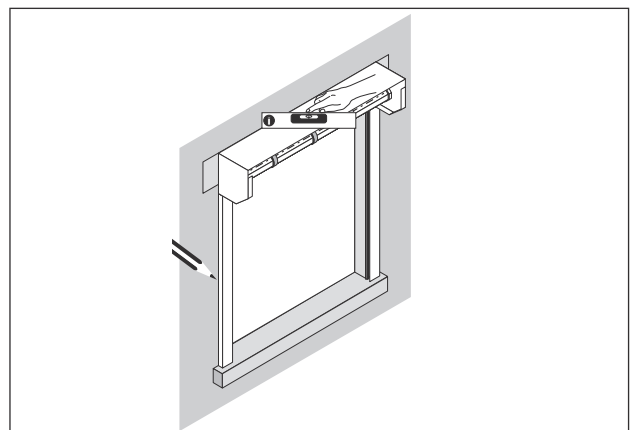

4 Offer the shutter to the opening and centralise, ensuring the top of the shutter box is horizontal and that both guide rails are vertical. Mark the guide location.

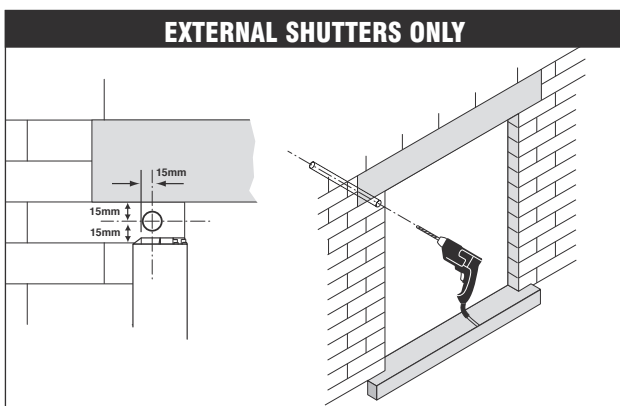

EXTERNAL SHUTTERS ONLY
5 Mark and drill the belt tube hole. Drill a 10mm pilot hole followed by a 22mm hole for the tube.
Tip – hold a block of wood against plaster to reduce damage caused by the drilling process.

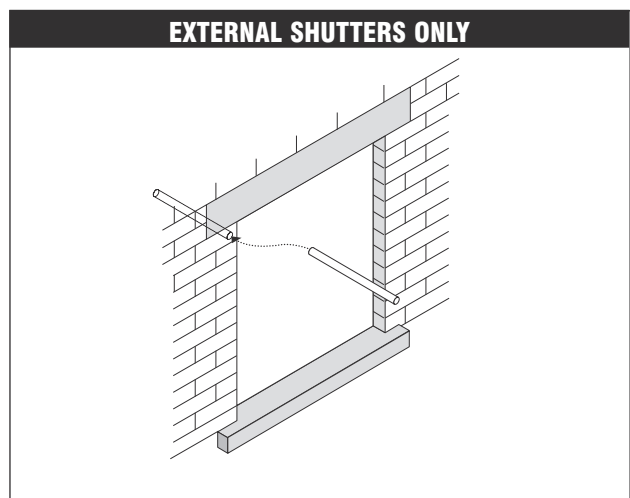

EXTERNAL SHUTTERS ONLY
6 Cut belt tube to correct length and insert

7.1 Manual Belt Operation Installation Instructions (cont.)

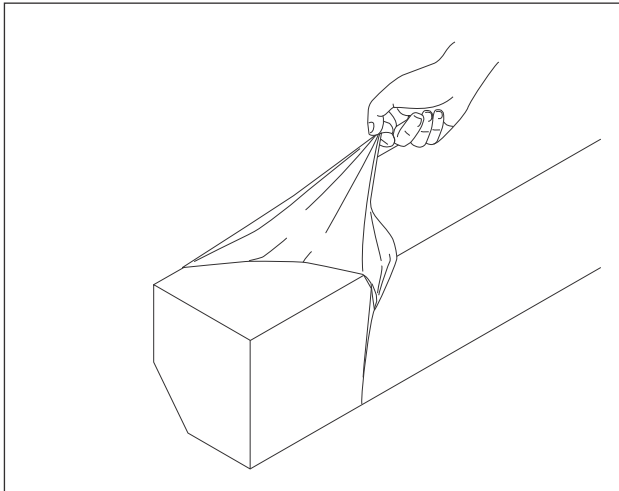

7 Remove film from box top

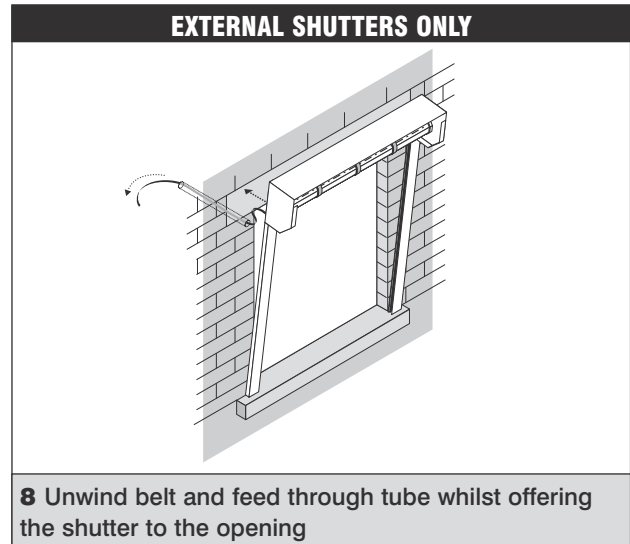

8 Unwind belt and feed through tube whilst offering the shutter to the opening

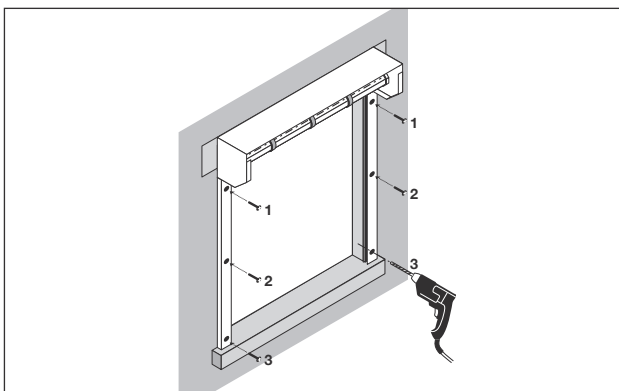

9 Starting with the top holes, fix the guide rails ensuring that the guide rails are vertical and that the shutter box is horizontal. Use the fixings recommended on page 8. 7mm hole right through then front hole enlarged to 13mm.

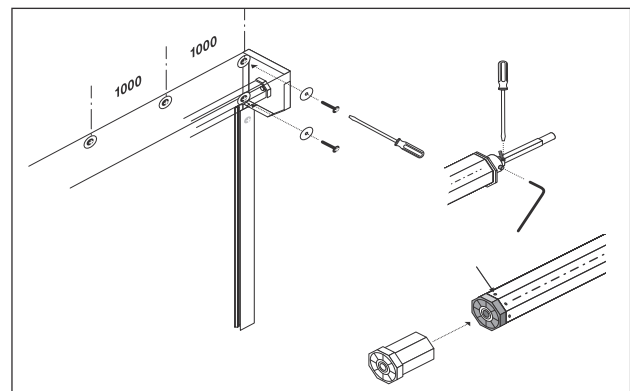

10 Fit the shutter box using the recommended fixings and spacings. Once the shutter box has been installed check the dummy end making sure that it is securely located within the axle. If the dummy end is a shaft bolt design make sure that the centre shaft is fixed in place so that it can not slide back into the axle.

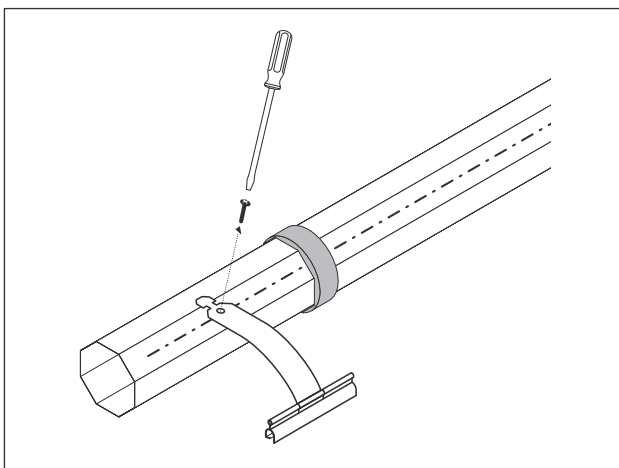

11 Remove locking springs and store safely for use in step 15

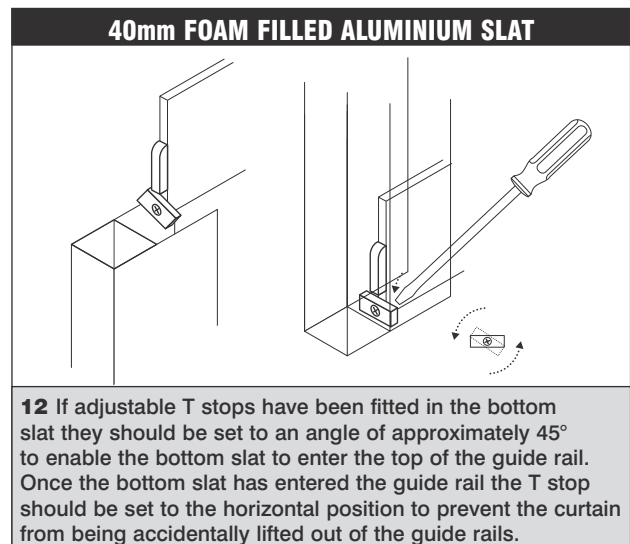

12 If adjustable T stops have been fitted in the bottom slat they should be set to an angle of approximately 45° to enable the bottom slat to enter the top of the guide rail. Once the bottom slat has entered the guide rail the T stop should be set to the horizontal position to prevent the curtain from being accidentally lifted out of the guide rails.

7.1 Manual Belt Operation Installation Instructions (cont.)

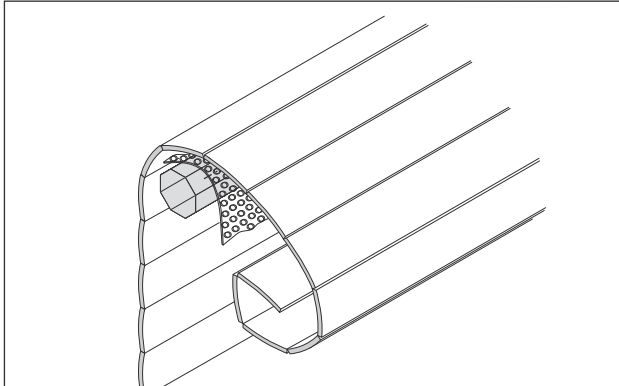

⚠ RISK OF MATERIAL DAMAGE!
13 Cover the axle with bubble wrap or a similar material to prevent the curtain from being damaged during the curtain loading process. Carefully load the curtain over the axle.

PLEASE NOTE LOCKING SPRINGS WILL NOT BE ATTACHED AT THIS STAGE, THIS IS DRAWING IS FOR ILLUSTRATIVE PURPOSES ONLY

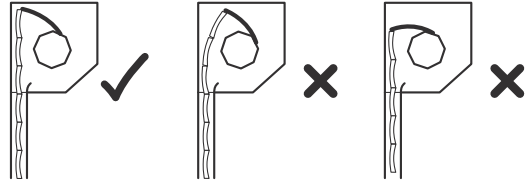

14 Check the curtain height. When pushed towards the back of the shutter box the curtain should finish just under the box top. If the curtain is too tall then slats should be removed to obtain the correct height. If the curtain finishes more than one slat beneath the shutter box top then the curtain is too short and the height must be increased in order for the shutter to lock correctly when fully down.

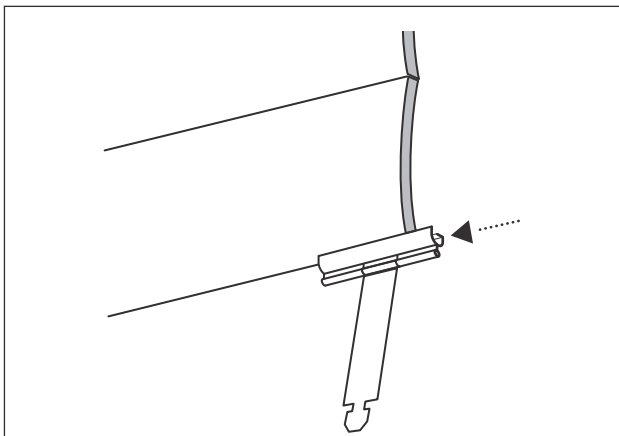

15 Load the locking springs onto the curtain

**LOCKING SPRINGS
 NO. 8 X 1/4 PAN FLANGE POZI – TYPE C**

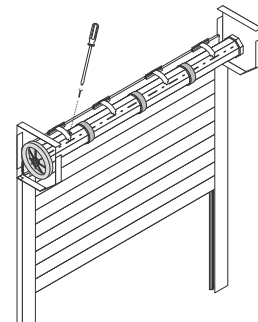

16 Before you attach the curtain to the axle you should determine where you will mount the winder then pull the belt wrapped around the drive wheel so that the belt will pass the winder by at least 400mm. Attach the locking springs to the axle using the screws supplied.

38mm EXTRUDED ALUMINIUM SLAT ONLY

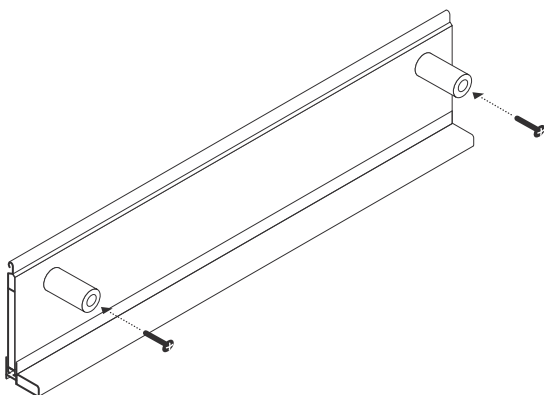

17 If stops or buffers have been supplied these can now be fitted to the bottom slat.

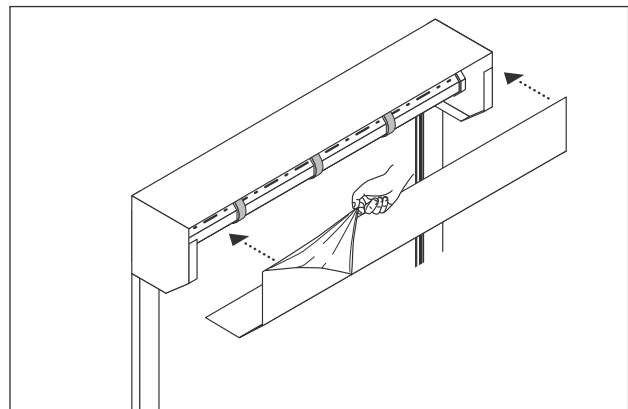

17 Remove the protective film from the box lid then fit the box lid to the shutter box. If the shutter is externally fitted the box lid should be fastened using appropriately coloured 4mm rivets.

7.1 Manual Belt Operation Installation Instructions (cont.)

EXTERNAL SHUTTERS ONLY

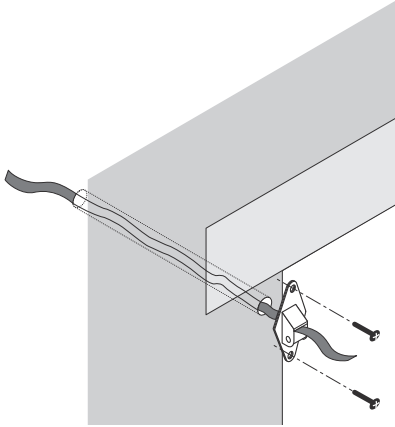

19 Slide roller on belt and mount on the internal wall.

INTERNAL SHUTTERS ONLY

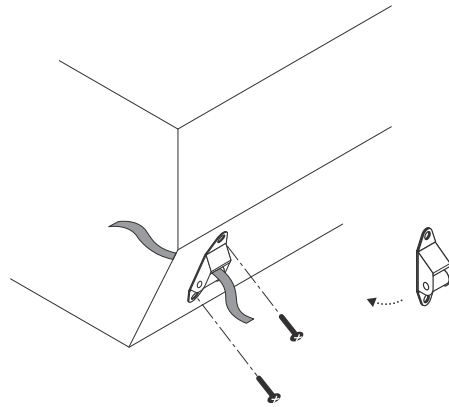

20 Slide roller on belt and mount.

SWIVEL BELT WINDER ONLY

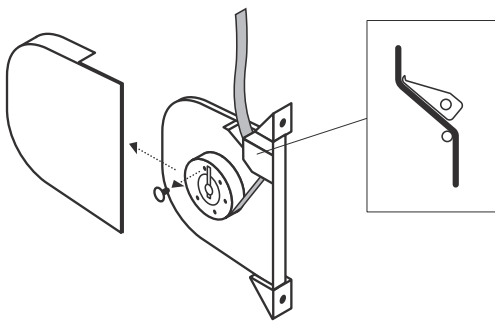

21 Load the belt into the winder. The belt will be supplied to the correct length. Pass the belt under the metal flap and between the chrome rollers. 500mm from the end of the belt cut a 10mm lengthways slit along the centre. Hook onto the pretensioned spring casing then release.

GEARED BELT WINDER ONLY

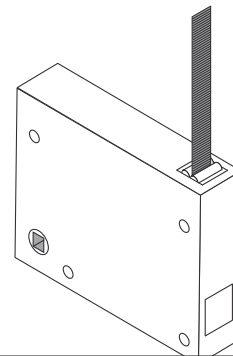

22 Load the belt into the winder. The belt will be supplied to the correct length. Take off the front of the winder, pass the belt between the rollers and fasten by knotting securely into the centre of the large cog. Reassemble the winder before fastening to the wall.

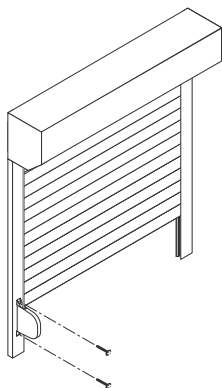

23 Mount the winder at a convenient height for operation either to the wall or to the guide rails as appropriate.

SWIVEL BELT WINDER ONLY

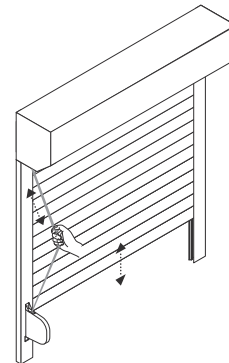

24 Test the operation of the winder and the shutter to ensure that the belt feeds into and out of the winder correctly and also that the shutter moves freely up and down in the guide rails.

7.1 Manual Belt Operation Installation Instructions (cont.)

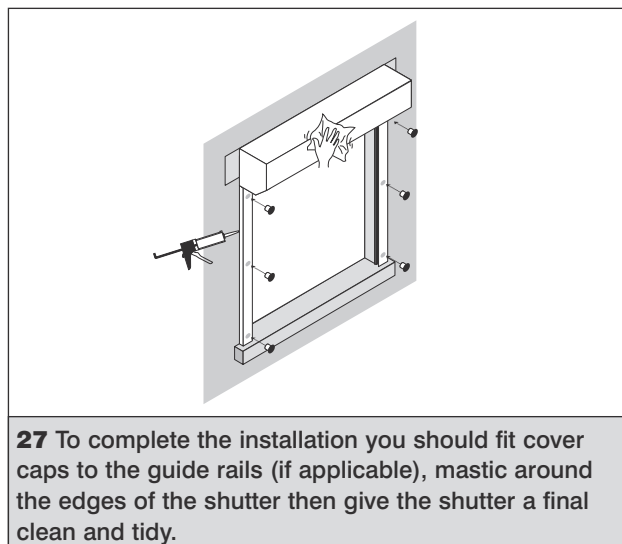
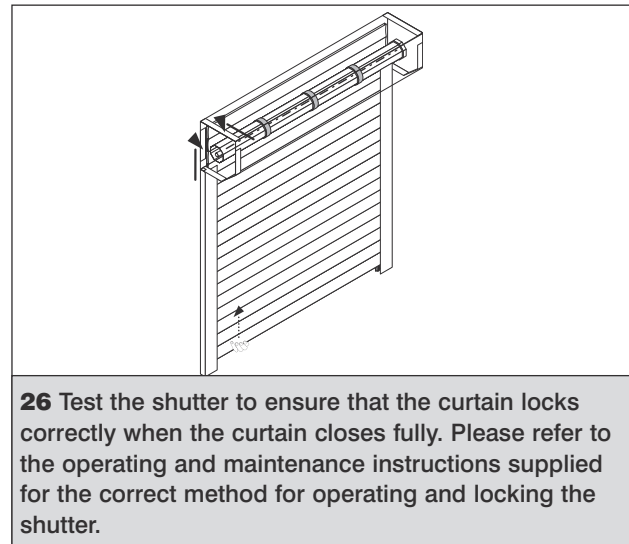
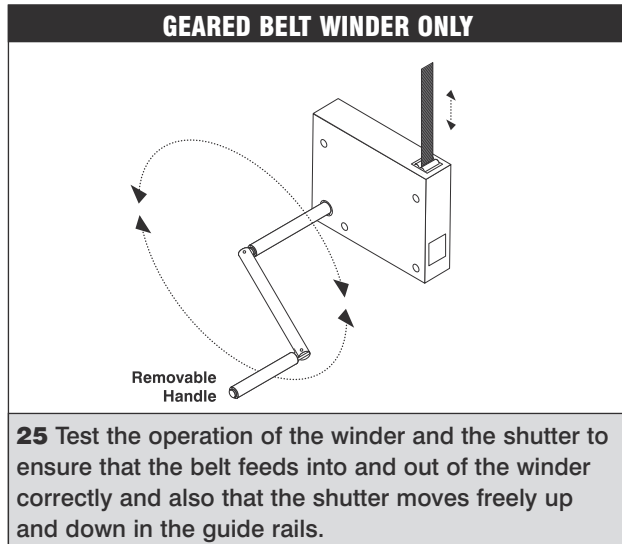

Upon completion of the installation the owner of the shutter must be trained how to operate the product safely paying special attention to the following points:

- The shutter should only be operated when in view
- The operator should ensure there are no objects or persons in the opening before and during operation.
- The end user must read and follow the advice given in the operating and maintenance instructions.
- In the event of a malfunction the end user should follow the advice given in the operating and maintenance instructions and if applicable contact the installer.

7.2 Rod Crank Operation Parts List

General Parts:

- Assembled shutter box (1 per shutter)
- Pair of guide rails (1 pair per shutter)
- Assembled curtain (1 per shutter)
- Installation instructions
- Operating & Maintenance instructions

Operation Specific Parts:

- Rod crank handle (1 per shutter)
- Rod crank handle clip (1 per shutter)

Accessories are packed in a separate box.

If applicable angle & packer are usually packed with the guide rails.

Guide to correct guide rail orientation

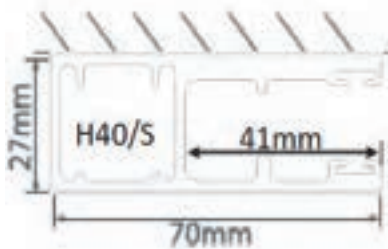

Certain guide rails have an internal and external face, due to their extrusion profile. These guide rails must be installed the correct way round. Please check the guide rails you have been supplied before you begin installing the shutter.

Rod crank and override handles

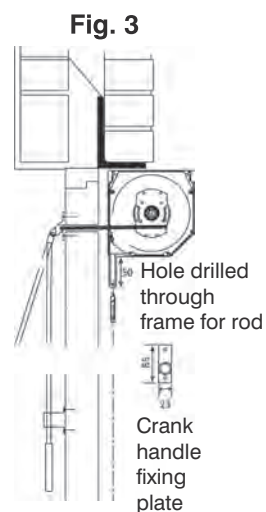
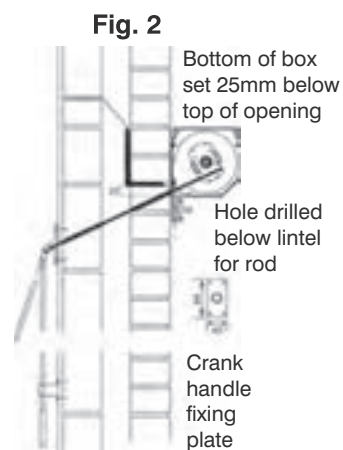
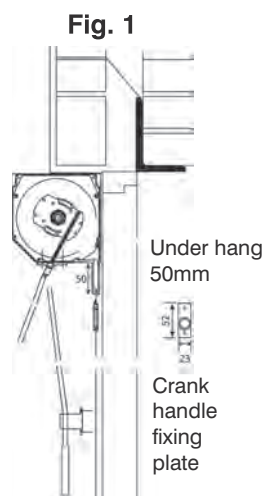

fig.1 is a 45° joint with 2 hole fixing plate, box exit F

fig.2 is a 90° joint with 4 hole fixing plate, box exit A

fig.3 is a 90° joint with 2 hole fixing plate, box exit H

7.2 Rod Crank Operation Installation instructions

Before you begin installing the shutter please ensure you have read pages 4–9.

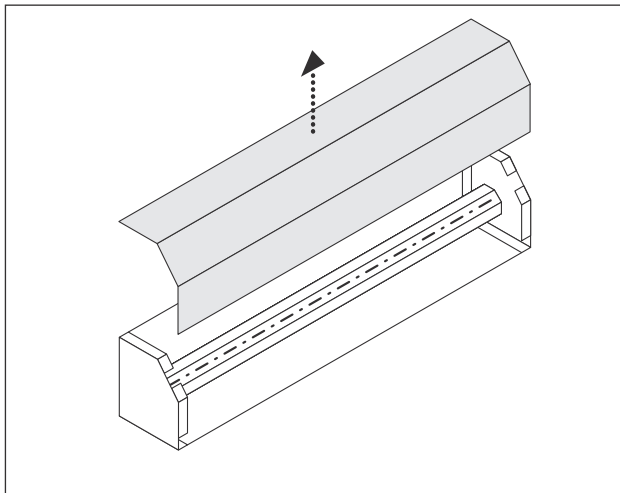

1 Remove lid from box

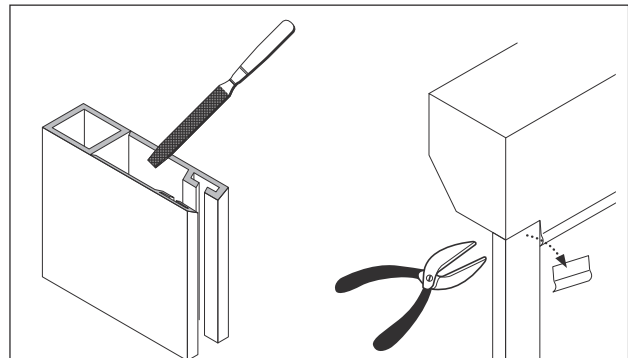

2 File the top of the guides at an angle to create the optimum lead in for the curtain. Guide insert should also be trimmed to suit the filed guide top and securely crimped in place. If the shutter is being face fitted remove the lip from the box back which overlaps the guide rails.

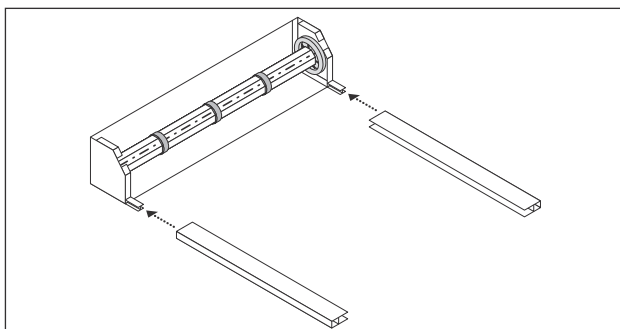

3 Carefully locate the guide rails onto the box lugs ensuring that on face fit guides the 13mm holes are on the outside. When moving the shutter as a complete unit you should take care to prevent the lugs being snapped off the box ends by the leverage available from the guide rails. If the shutter is too large to be lifted up as a complete unit you should offer up, locate and fix the individual guide rails then the shutter box.

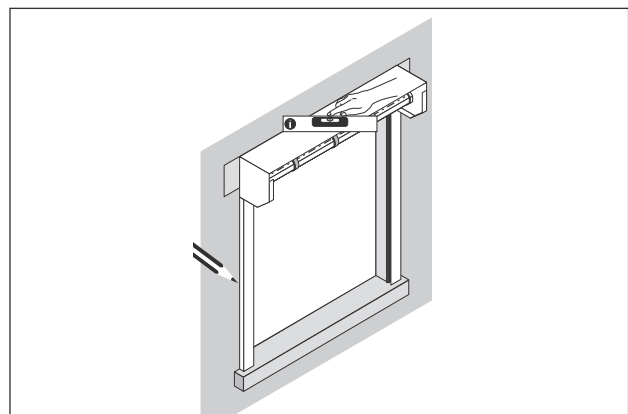

4 Offer the shutter to the opening and centralise, ensuring the top of the shutter box is horizontal and that both guide rails are vertical. Mark the guide location.

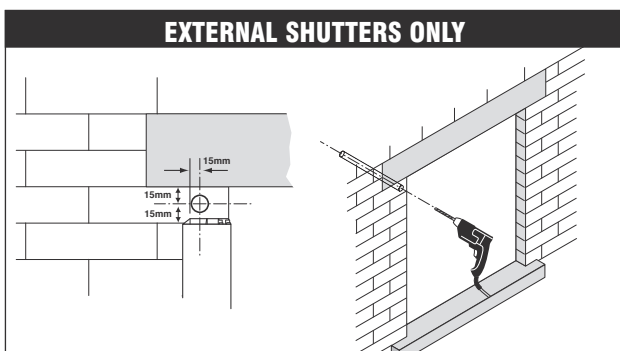

5 Mark and drill the rod crank hole. Refer to step 6 to determine the angle of the crank hole. Please note the shutter box is not shown in this diagram. The location of the hole is determined by the exit hole in the shutter box. Drill a 10mm pilot hole followed by a 22mm hole for the tube.



Tip – hold a block of wood against plaster to reduce damage caused by the drilling process.

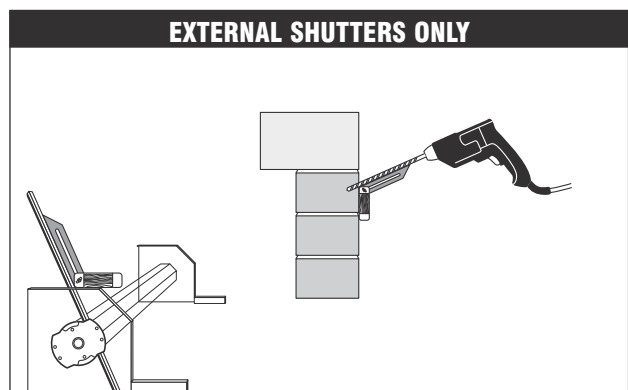

6 Determine the angle of the crank hole.

7.2 Rod Crank Operation Installation instructions (cont.)

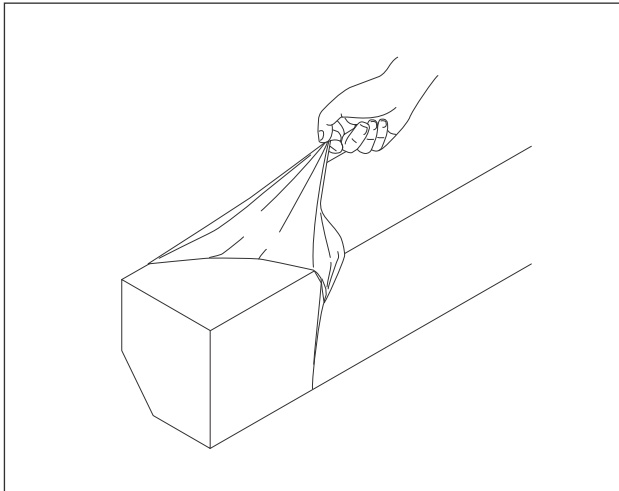

7 Remove film from box top

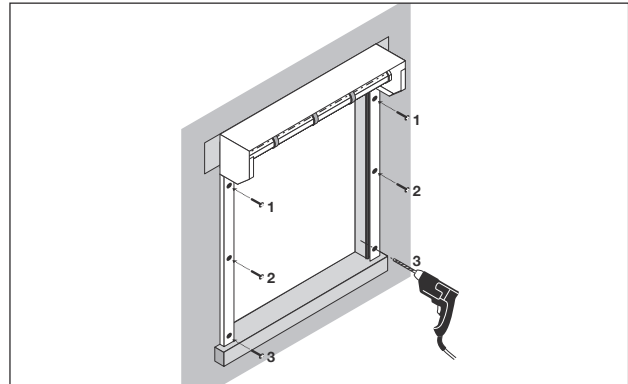

8 Starting with the top holes, fix the guide rails ensuring that the guide rails are vertical and that the shutter box is horizontal. Use the fixings recommended on page 8. 7mm hole right through then front hole enlarged to 13mm.

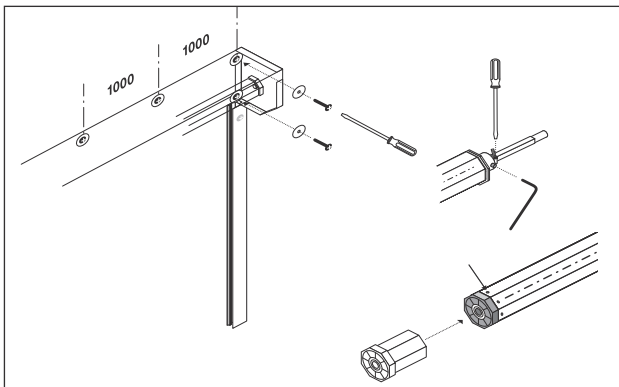

9 Fit the shutter box using the recommended fixings and spacings. Once the shutter box has been installed check the dummy end making sure that it is securely located within the axle. If the dummy end is a shaft bolt design make sure that the centre shaft is fixed in place so that it can not slide back into the axle.

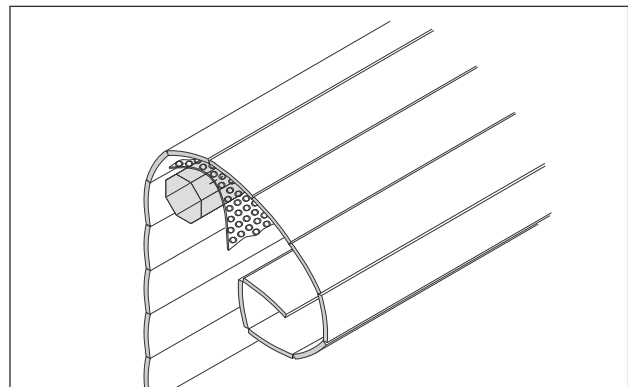

⚠ RISK OF MATERIAL DAMAGE!
10 Cover the axle with bubble wrap or a similar material to prevent the curtain from being damaged during the curtain loading process. Carefully load the curtain over the axle.

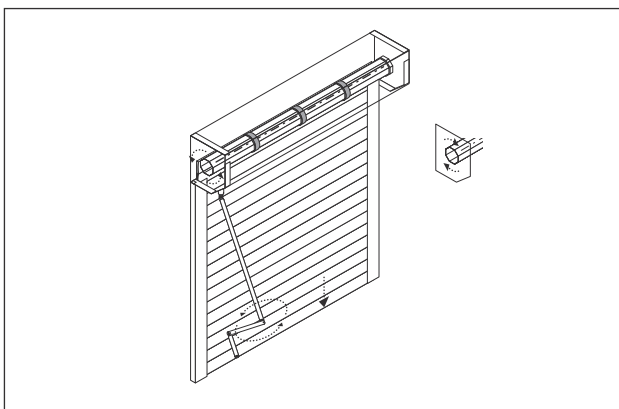

11 The crank gear contains a stop to prevent the shutter from being overwound when it reaches the bottom. Wind the crank gear to the bottom stop then wind back ½ a turn.

CURTAINS DIRECT TO AXLE NO. 10 X ½ PAN POZI – TYPE C

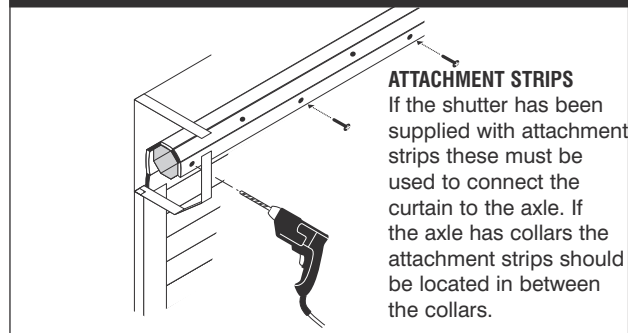

ATTACHMENT STRIPS
 If the shutter has been supplied with attachment strips these must be used to connect the curtain to the axle. If the axle has collars the attachment strips should be located in between the collars.

12 Attach the top two slats of the curtain directly to the axle using the screws provided. The screws must be countersunk to prevent them damaging the slats which will coil on top.

7.2 Rod Crank Operation Installation instructions (cont.)

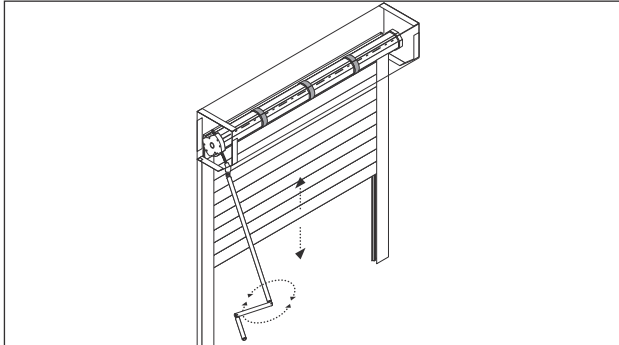

13 Insert the crank handle temporarily and slowly wind the handle to test the operation of the shutter. Test the shutter to ensure that the curtain locks correctly when the curtain closes fully. Please refer to the operating and maintenance instructions supplied for the correct method for operating and locking the shutter. Ensure that the shutter moves freely up and down in the guide rails.

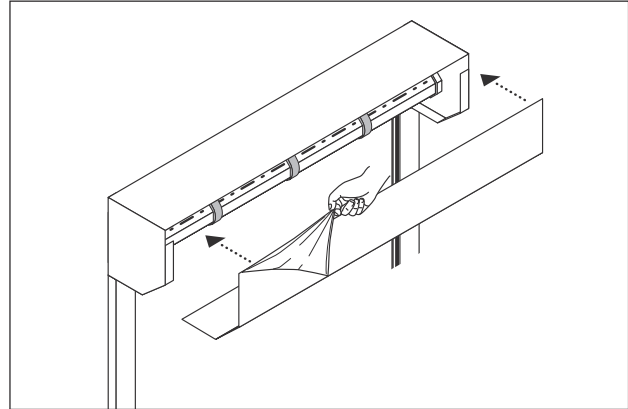

14 Remove the protective film from the box lid then fit the box lid to the shutter box. If the shutter is externally fitted the box lid should be fastened using appropriately coloured 4mm rivets.

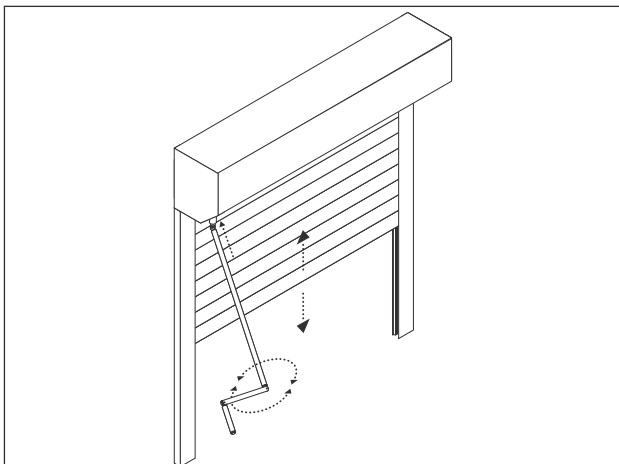

15 The crank handle should now be permanently attached to the shutter.

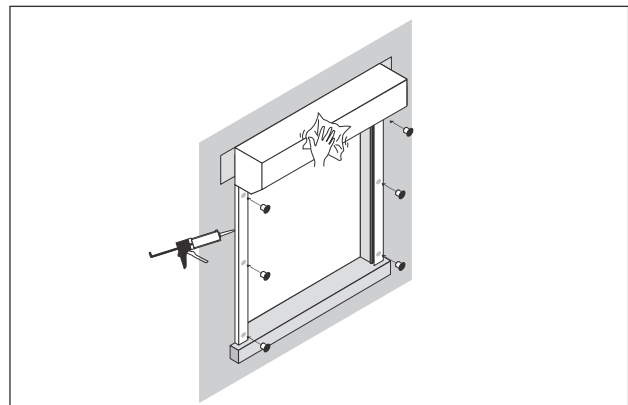

16 To complete the installation you should fit cover caps to the guide rails (if applicable), mastic around the edges of the shutter then give the shutter a final clean and tidy.

Upon completion of the installation the owner of the shutter must be trained how to operate the product safely paying special attention to the following points:

- The shutter should only be operated when in view
- The operator should ensure there are no objects or persons in the opening before and during operation.
- The end user must read and follow the advice given in the operating and maintenance instructions.
- In the event of a malfunction the end user should follow the advice given in the operating and maintenance instructions and if applicable contact the installer.

7.3 Spring Loaded Operation Parts list

General Parts

- Assembled shutter box (1 per shutter)
- Pair of guide rails (1 pair per shutter)
- Assembled curtain (1 per shutter)
- Installation instructions
- Operating & Maintenance instructions

Keys for bottom slat locks are packed in a bag which is taped to the bottom slat.

Accessories are packed in a separate box.

If applicable angle & packer are usually packed with the guide rails.

Guide to correct guide rail orientation

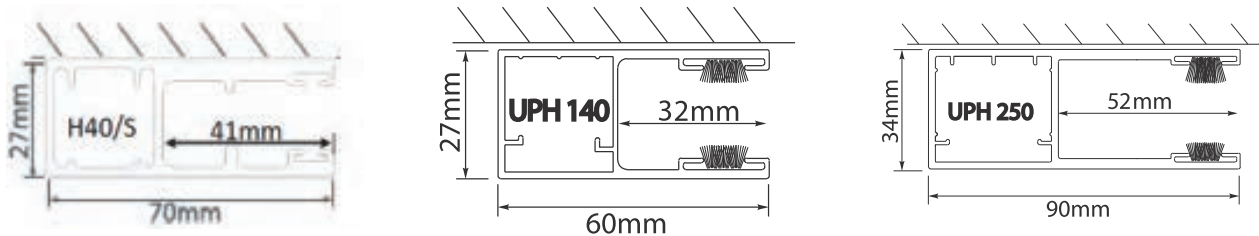

Certain guide rails have an internal and external face, due to their extrusion profile. These guide rails must be installed the correct way round. Please check the guide rails you have been supplied before you begin installing the shutter.

If keeps have been prepared in the guide rails for the bottom slat lock bar you must ensure that the guide rails are orientated so that the keeps are at the base of the guide rails as shown below.

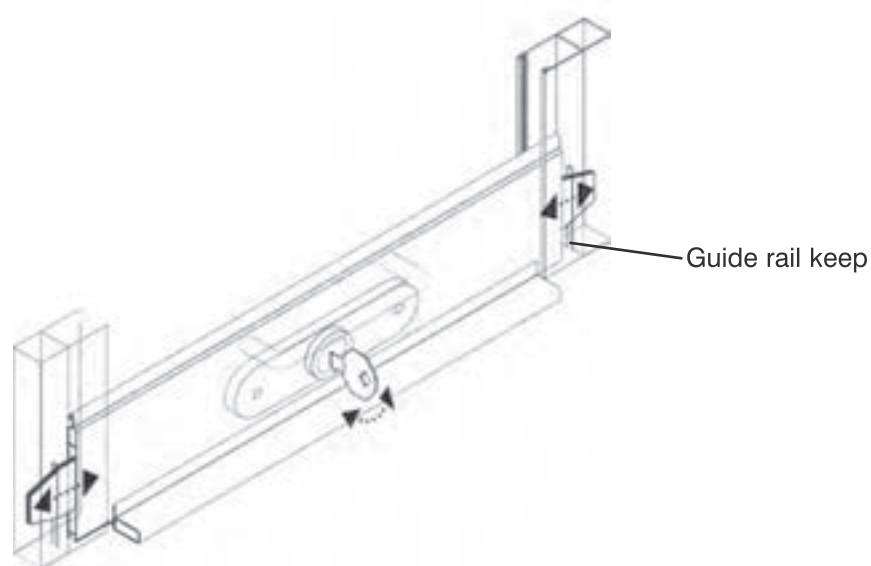

7.3 Spring Loaded Operation Installation Instructions

Before you begin installing the shutter please ensure you have read pages 4–9.

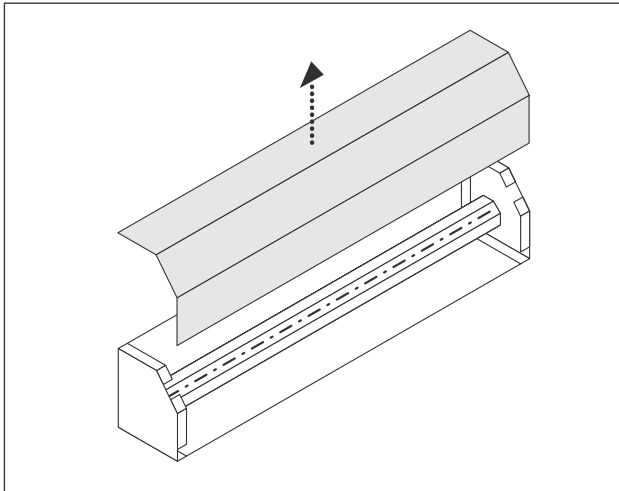

1 Remove lid from box

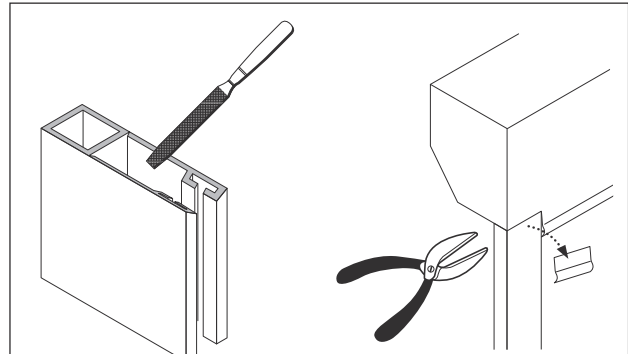

2 File the top of the guides at an angle to create the optimum lead in for the curtain. Guide insert should also be trimmed to suit the filed guide top and securely crimped in place. If the shutter is being face fitted remove the lip from the box back which overlaps the guide rails.

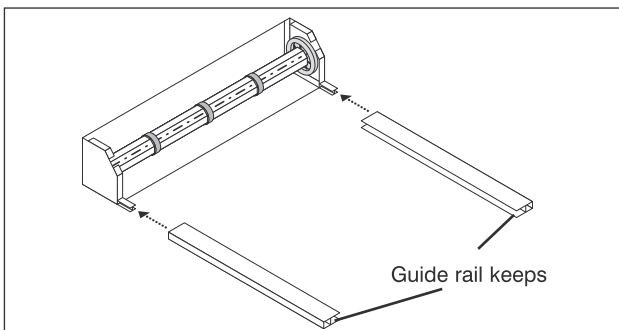

3 Carefully locate the guide rails onto the box lugs ensuring that on face fit guides the 13mm holes are on the outside. When moving the shutter as a complete unit you should take care to prevent the lugs being snapped off the box ends by the leverage available from the guide rails. If the shutter is too large to be lifted up as a complete unit you should offer up, locate and fix the individual guide rails then the shutter box.

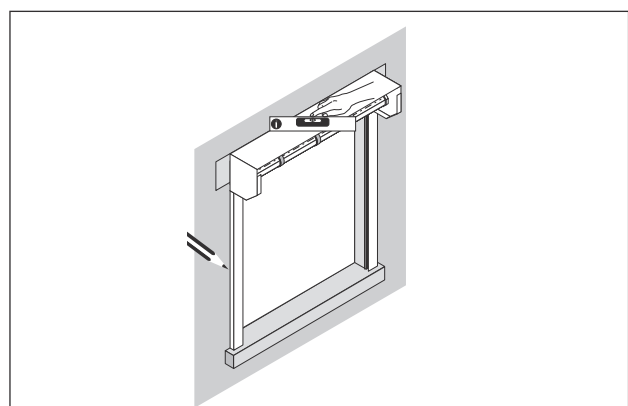

4 Offer the shutter to the opening and centralise, ensuring the top of the shutter box is horizontal and that both guide rails are vertical. Mark the guide location.

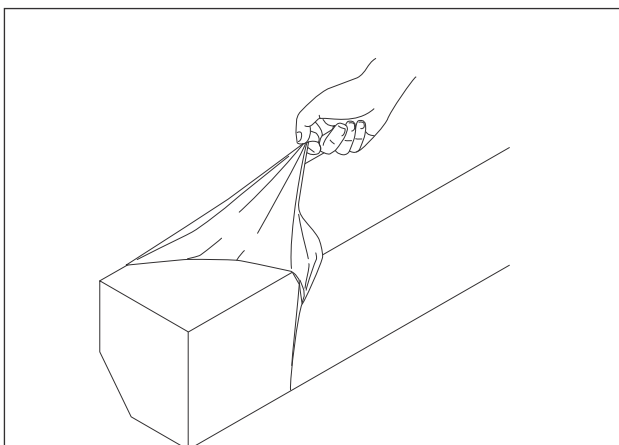

5 remove film from box top

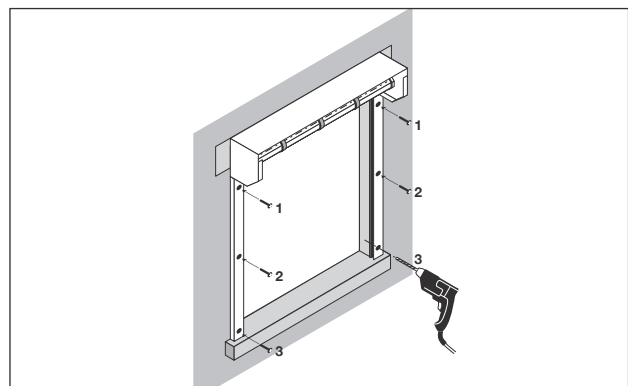

6 Starting with the top holes, fix the guide rails ensuring that the guide rails are vertical and that the shutter box is horizontal. Use the fixings recommended on page 8. 7mm hole right through then front hole enlarged to 13mm.

7.3 Spring Loaded Operation Installation Instructions (cont.)

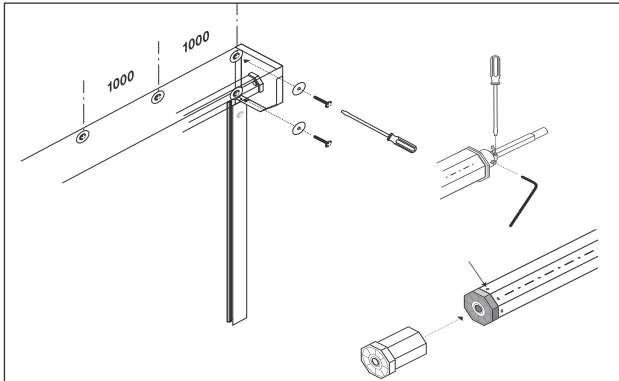

7 Fit the shutter box using the recommended fixings and spacings. Once the shutter box has been installed check the dummy end making sure that it is securely located within the axle. If the dummy end is a shaft bolt design make sure that the centre shaft is fixed in place so that it can not slide back into the axle.

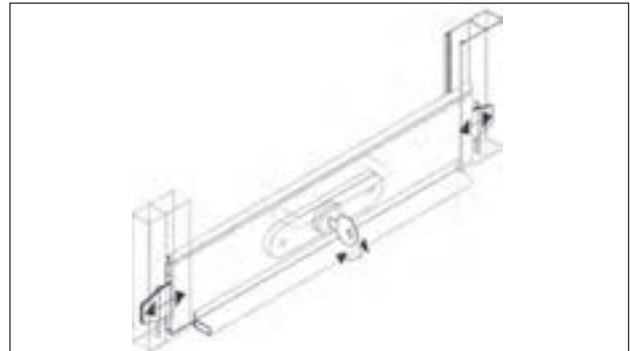

8 If shoot bolts or a lock have been supplied in the bottom slat you should remove the bottom slat from the curtain. Slide the bottom slat down into the guide rails and check that the lock bars in the bottom slat will locate into the prepared guide rail keeps. Enlarge the keeps if necessary.

ONLY APPLICABLE IF LOCK POSITIONED ABOVE THE BOTTOM SLAT

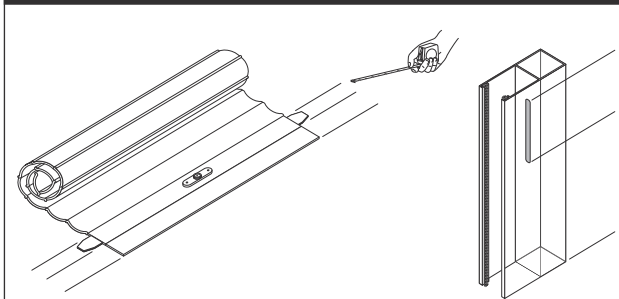

9 If the curtain contains a lock installed in a slat above the bottom slat you will need to prepare the guide rails for the lock bar, which will protrude from the slat when the lock is operated. Measure the distance from the bottom of the curtain to the lock bar then create a hole in each guide rail to suit the lock bar.

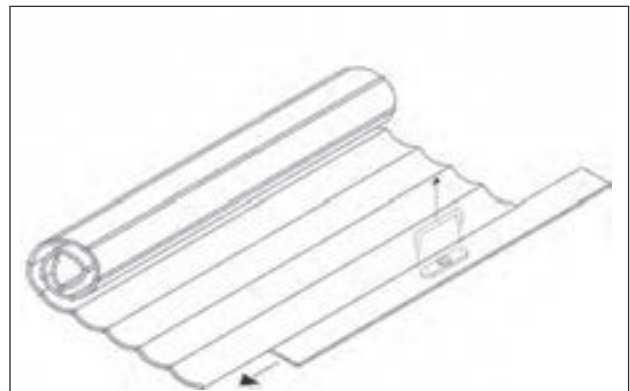

10 To prevent damage to the shutter and the surroundings and also to make the following step easier, remove the handles and stops from the bottom slat. Reattach the bottom slat to the curtain. If necessary remove the bottom slat handle from the bottom slat.

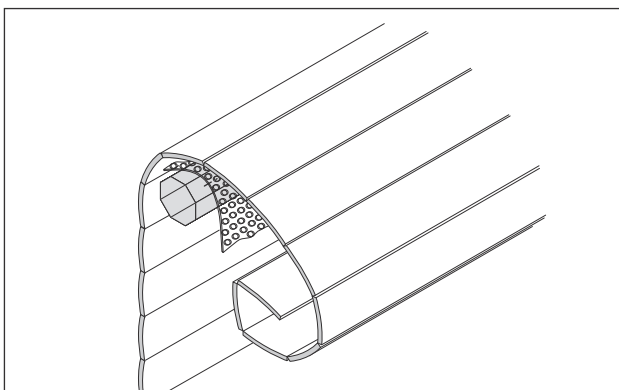

⚠ RISK OF MATERIAL DAMAGE!
11 Cover the axle with bubble wrap or a similar material to prevent the curtain from being damaged during the curtain loading process. Carefully load the curtain over the axle.

CURTAINS DIRECT TO AXLE NO. 10 X 1/2 PAN POZI – TYPE C

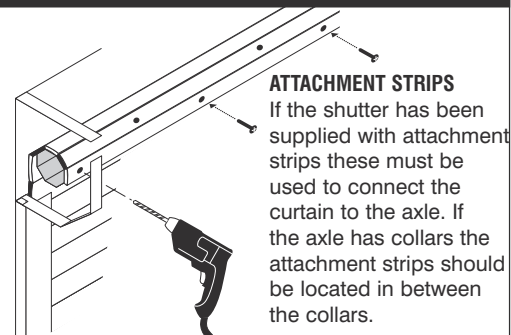

12 Attach the curtain directly to the axle through the top two slats using the screws provided. Do not use locking springs. Screw heads must be countersunk to prevent damage to the curtain.

7.3 Spring Loaded Operation Installation Instructions (cont.)

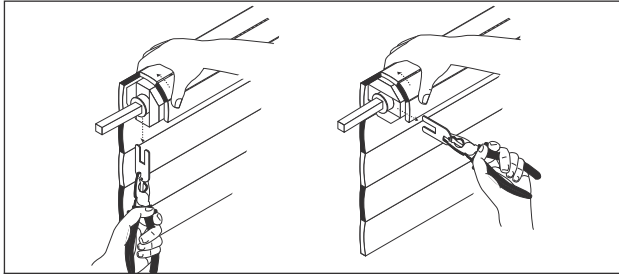

RISK OF PERSONAL INJURY!

13 Turn the axle in the down direction and carefully remove the pin. Please note there may be tension on the spring, which will cause the axle to turn. If the shutter contains a second anti-fall back spring (double spring) only one of the springs should be supplied with a pin. The shutter should be installed in the same way as a standard spring loaded shutter.



TIP - Lock the bottom slat to prevent the curtain from lifting and the axle from turning

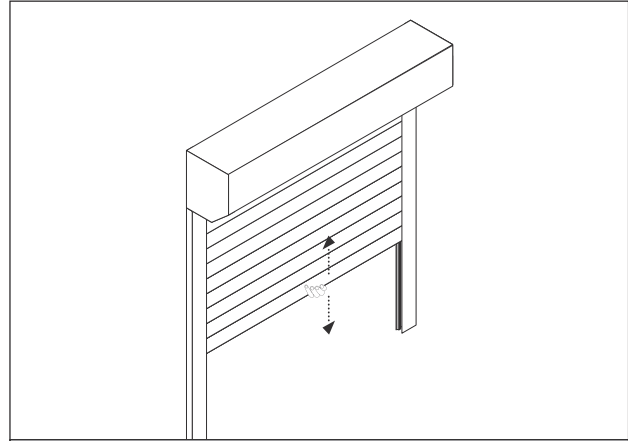

RISK OF MATERIAL DAMAGE!

14 Test the operation keeping hold of the bottom slat at all times.

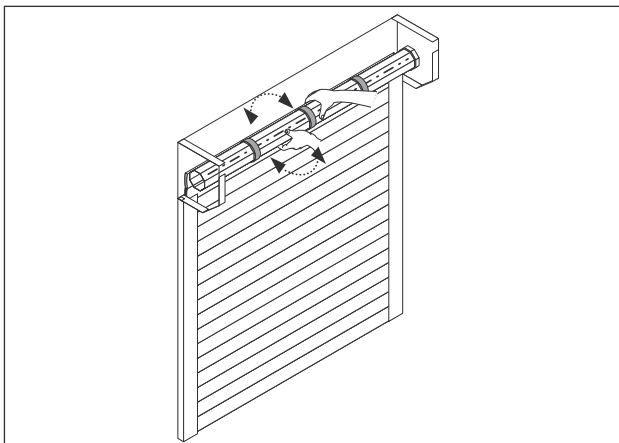

15 If required adjust the tension in the spring.

Method 1:

Lift the curtain to the top so that it coils around the axle. Place cardboard between the lock and the curtain to prevent the lock from damaging the curtain. Now allow the bottom slat to come out of the top of the guides so that you can rotate the coil to add to or release the tension in the spring. To add tension to the spring turn the axle in the down direction.

To release tension from the spring turn the axle in the up direction.

Once adjusted feed the curtain back into the guide rails and test the operation. Repeat this process until the spring contains the correct amount of tension.

Method 2:

Lower the curtain to the floor. Turn the axle forward and insert the pin in the end of the spring to lock the axle (reverse of step 14). Detach the curtain from the axle. Carefully remove the pin then add or remove tension from the spring as appropriate.

To add tension to the spring turn the axle in the down direction.

To release tension from the spring turn the axle in the up direction.

Once adjusted replace the pin then continue as step 13.

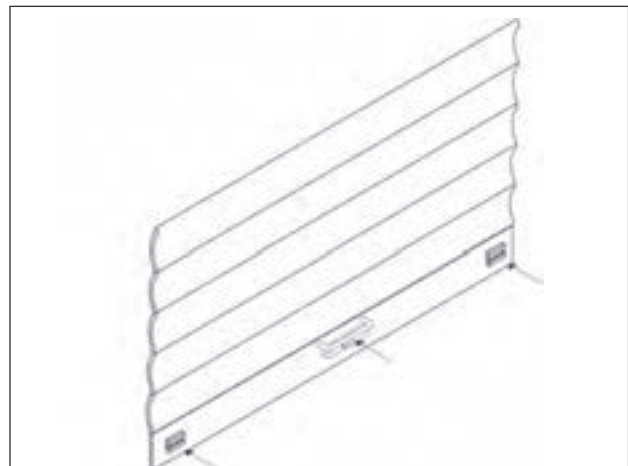

16 Attach the stops, handles and bottom slat handle removed earlier.

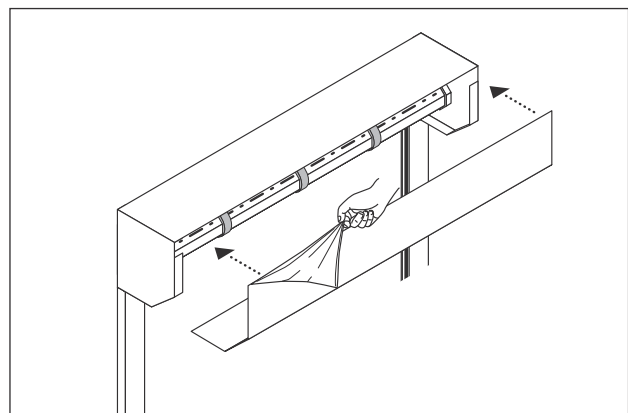

17 Remove the protective film from the box lid then fit the box lid to the shutter box. If the shutter is externally fitted the box lid should be fastened using appropriately coloured 4mm rivets.

7.3 Spring Loaded Operation Installation Instructions (cont.)

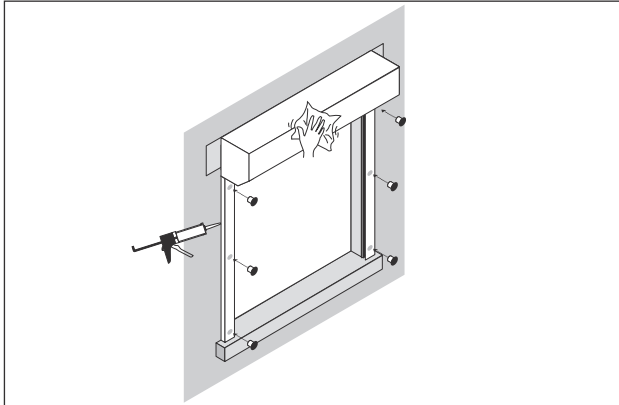

18 To complete the installation you should fit cover caps to the guide rails (if applicable), mastic around the edges of the shutter then give the shutter a final clean and tidy.

Upon completion of the installation the owner of the shutter must be trained how to operate the product safely paying special attention to the following points:

- **The shutter should only be operated when in view**
- **The operator should ensure there are no objects or persons in the opening before and during operation.**
- **The end user must read and follow the advice given in the operating and maintenance instructions.**
- **In the event of a malfunction the end user should follow the advice given in the operating and maintenance instructions and if applicable contact the installer.**

7.4 Electric operation Parts List

General Parts

- Assembled shutter box (1 per shutter)
- Pair of guide rails (1 pair per shutter)
- Assembled curtain (depending on the shutter size may be supplied in sections)
- Installation instructions
- Operating & Maintenance instructions

Accessories are packed in a separate box.

If applicable angle & packer are usually packed with the guide rails.

Operation Specific Parts

- Override handle (1 per shutter if manual override)
- Override handle clip (1 per shutter if manual override)
- Electric control method (depends on method requested):
- Switch (with back box surface / flush)
- Key switch
- Remote control kit
- Group command
- Battery back up

Guide to correct guide rail orientation

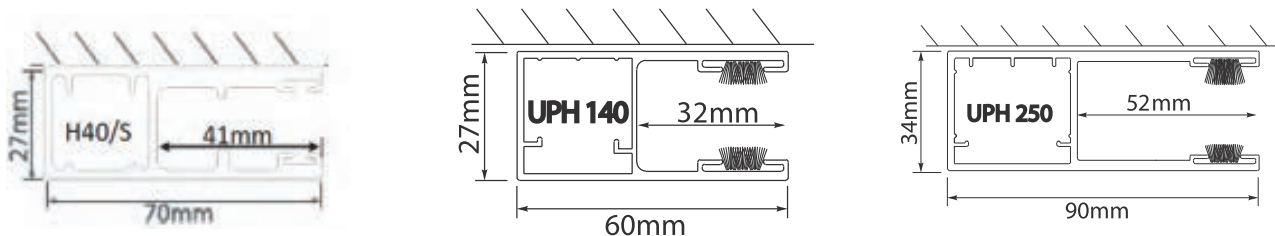

Certain guide rails have an internal and external face, due to their extrusion profile. These guide rails must be installed the correct way round. Please check the guide rails you have been supplied before you begin installing the shutter.

Rod crank and override handles

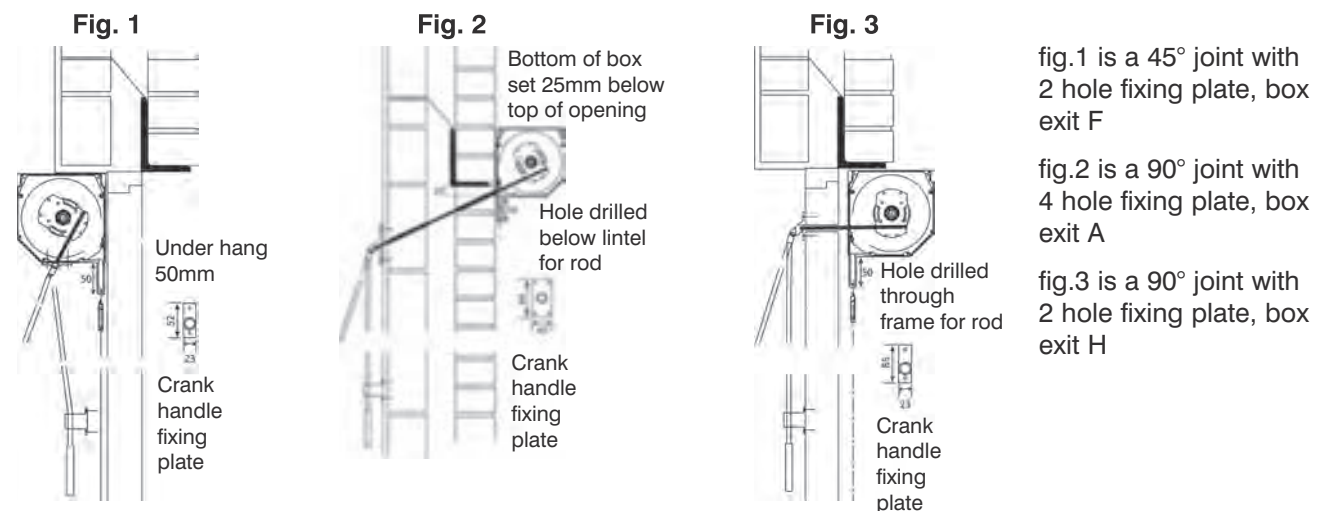

Override Crook

Rigid Eye Joint

Drop Eye Joint

7.4 Electric operation Installation Instructions

Before you begin installing the shutter please ensure you have read pages 4–9.

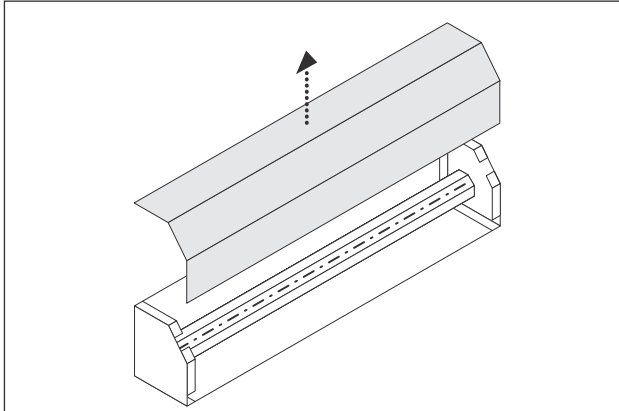

1 Remove the lid from the shutter box. If attached remove locking springs / attachment straps from the axle and keep safe for step 12.

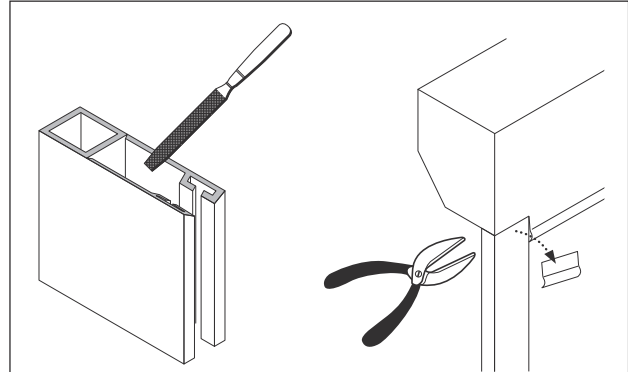

2 File the top of the guides at an angle to create the optimum lead in for the curtain. Guide insert should also be trimmed to suit the filed guide tops. If the shutter is being face fitted remove the lip from the box back which overlaps the guide rails.

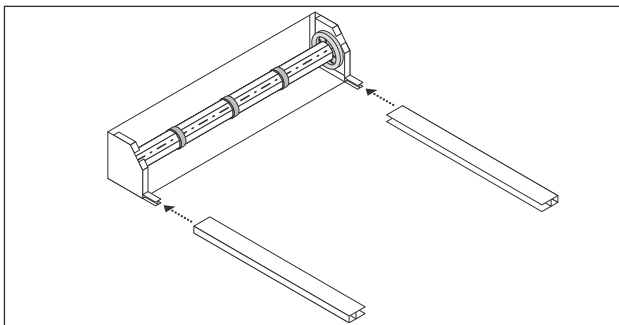

3 Carefully locate the guide rails onto the box lugs ensuring that on face fit guides the 13mm holes are on the outside. When moving the shutter as a complete unit you should take care to prevent the lugs being snapped off the box ends by the leverage available from the guide rails. If the shutter is too large to be lifted up as a complete unit you should offer up, locate and fix the individual guide rails then the shutter box.

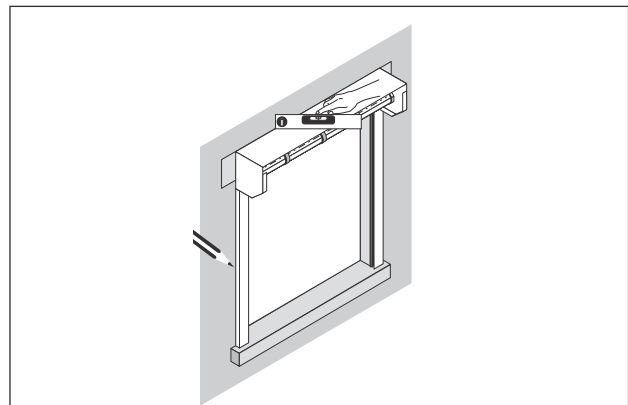

4 Offer the shutter to the opening and centralise, ensuring the top of the shutter box is horizontal and that both guide rails are vertical. Mark the guide location.

EXTERNAL SHUTTERS ONLY

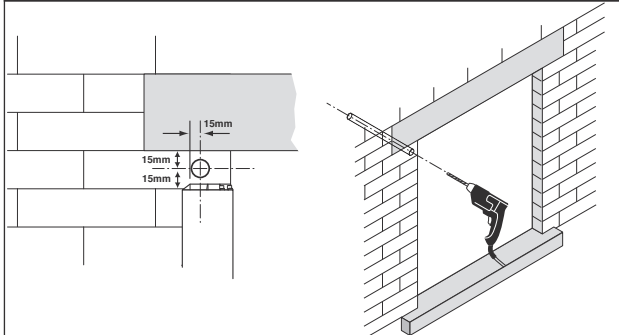

5 If applicable mark and drill the override hole ensuring the hole is drilled at the correct angle (see step 6). Drill a 10mm pilot hole followed by a 22mm hole

 **Tip** – hold a block of wood against plaster to reduce damage caused by the drilling process

EXTERNAL SHUTTERS ONLY

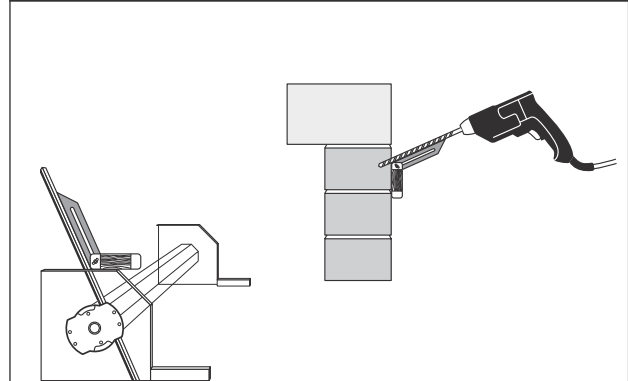

6 If a manual override has been supplied and if applicable determine the angle of the override hole.

7.4 Electric operation Installation Instructions (cont.)

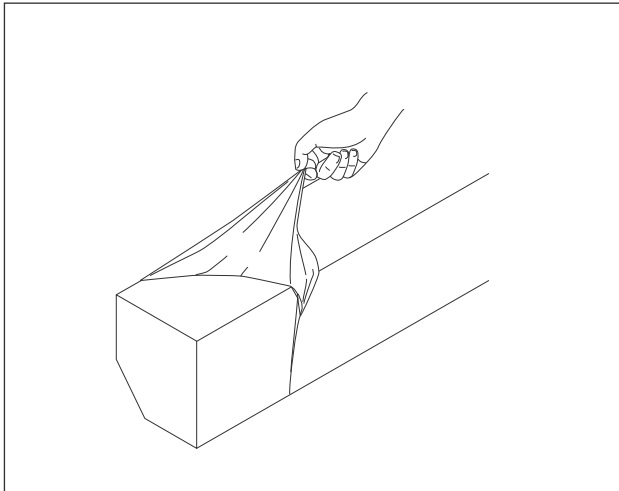

7 Remove film from box top

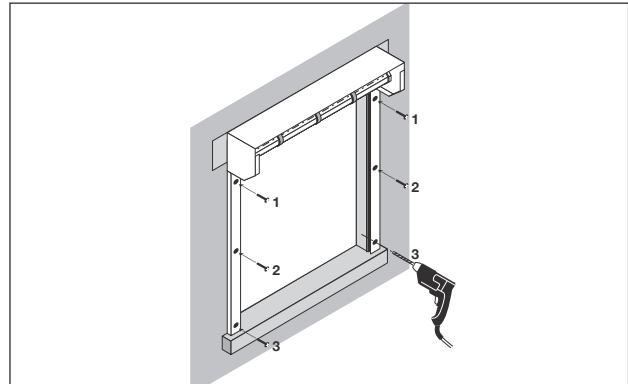

8 Starting with the top holes, fix the guide rails ensuring that the guide rails are vertical and that the shutter box is horizontal. Use the fixings recommended on page 8. 7mm hole right through then front hole enlarged to 13mm.

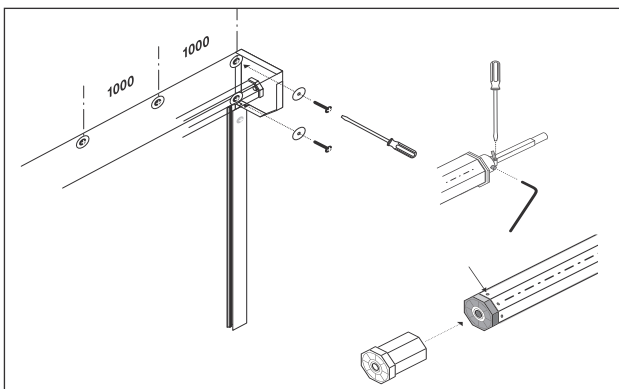

9 Fit the shutter box using the recommended fixings and spacings. Once the shutter box has been installed check the dummy end making sure that it is securely located within the axle. If the dummy end is a shaft bolt design make sure that the centre shaft is fixed in place so that it can not slide back into the axle.

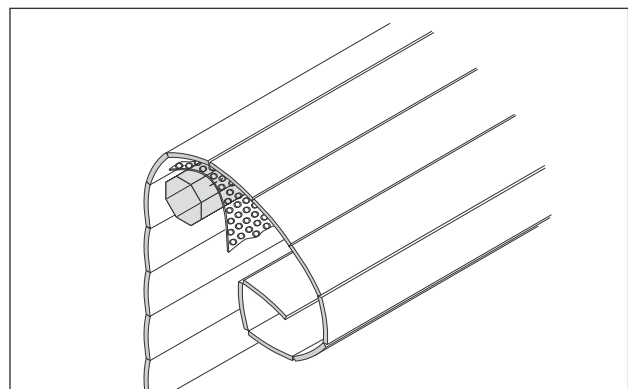

⚠ RISK OF MATERIAL DAMAGE
10 Cover the axle with bubble wrap or a similar material to prevent the curtain from being damaged during the curtain loading process. Carefully load the curtain over the axle.

PLEASE NOTE LOCKING SPRINGS WILL NOT BE ATTACHED AT THIS STAGE, THIS IS DRAWING IS FOR ILLUSTRATIVE PURPOSES ONLY

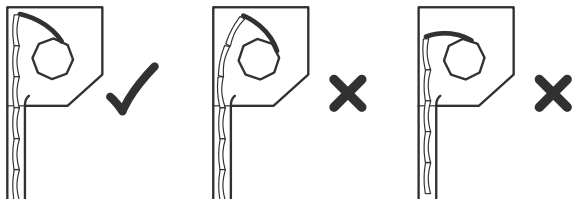

11 Check the curtain height. When pushed towards the back of the shutter box the curtain should finish just under the box top. If the curtain is too tall then slats should be removed to obtain the correct height. If the curtain finishes more than one slat beneath the shutter box top then the curtain is too short and the height must be increased in order for the shutter to lock correctly when fully down.

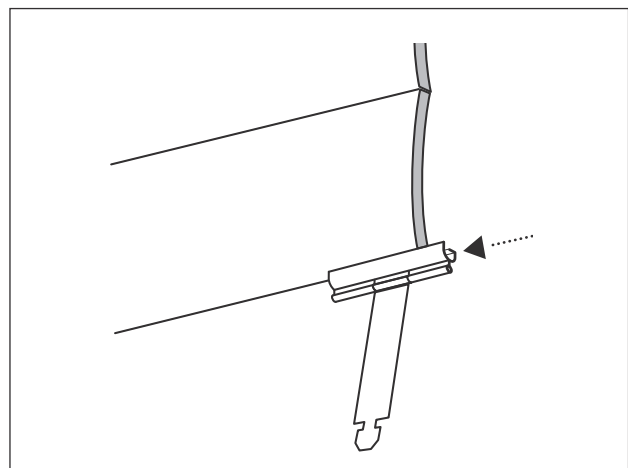

12 Load the locking springs / attachment straps onto the curtain.

7.4 Electric operation Installation Instructions (cont.)

LOCKING SPRINGS – NO. 8 X ¼ PAN FLANGE POZI – TYPE C ATTACHMENT STRIPS– NO. 10 X ¾ PAN POZI – TYPE C

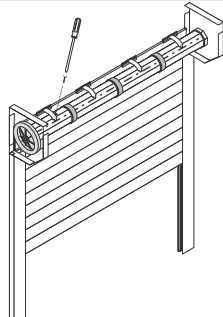

ATTACHMENT STRIPS
If the shutter has been supplied with attachment strips these must be used to connect the curtain to the axle. If the axle has collars the attachment strips should be located in between the collars.

13 Please note if this shutter has been supplied with an anti-fall back spring then the spring should be tensioned before you attach the curtain to the axle (see section 13.2)
Attach the locking springs / attachment strips to the axle using the screws supplied.

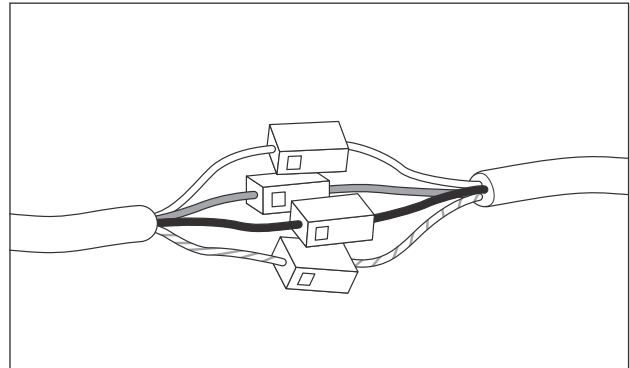

14 It is recommended that you use a test lead to set the motor limits or if a remote control is being supplied set the remote control into commissioning mode (see section 11.2). If a remote control is not being used or if you do not have a motor test lead the motor should now be wired to the switch supplied (see section 11).



- Failure to fix the shutter vertically or squarely can result in safety brake activation.

- The safety brake can also be activated if the shutter box is not fitted with sufficient fixings at sufficient intervals.

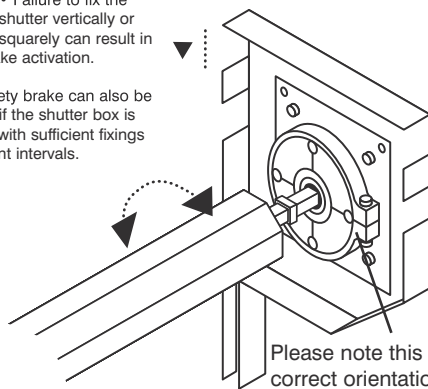

Please note this is not the correct orientation please refer to section 13

15 If applicable check anti-fall back device (see section 13.1 page 68)

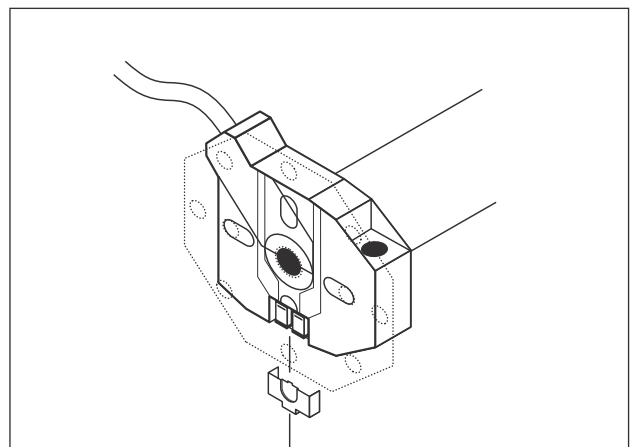

16 Set the motor limits (see section 12)

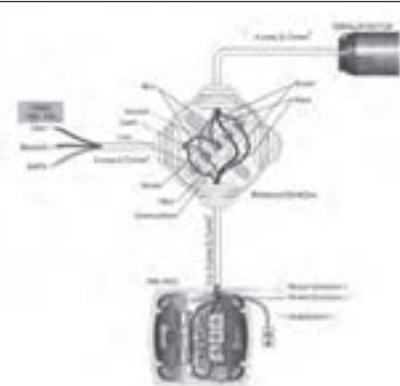

17 Wire the control method supplied to the shutter (see section 11 for further details). If an anti-drop brake has been supplied with a micro limit switch (wire attached to the anti-drop brake) this will also require wiring in at this stage (see section 13.1).

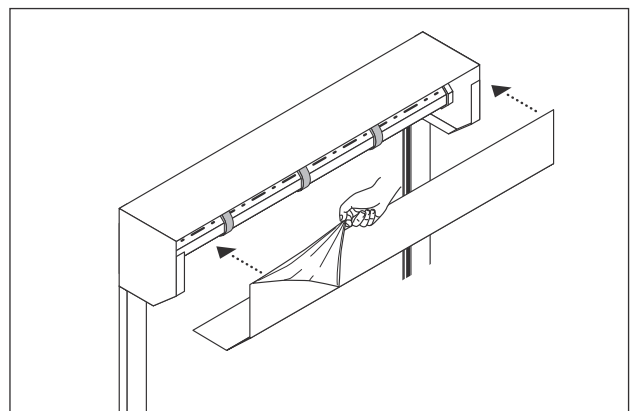

18 Remove the protective film from the box lid then fit the box lid to the shutter box. If the shutter is externally fitted the box lid should be fastened using appropriately coloured 4mm rivets.

7.4 Electric operation Installation Instructions (cont.)

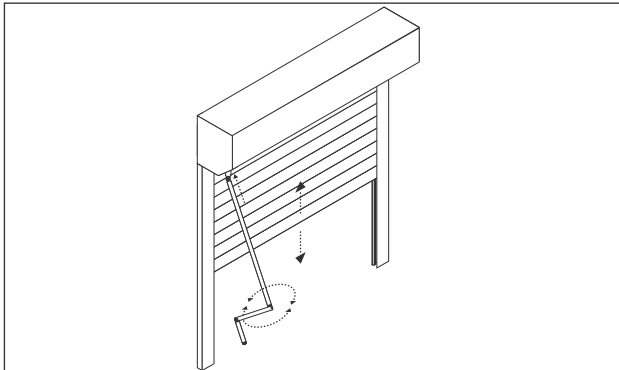

19 If applicable attach the override handle / rigid eye / drop eye to the shutter and test the manual override facility. Once you have identified which direction will open the shutter attach the label supplied to the override handle showing the end user which direction to wind the manual override to operate the shutter.

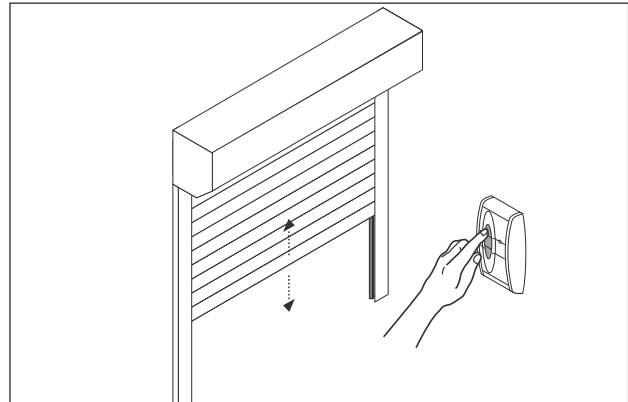

20 Test the operation of the shutter to ensure that the shutter moves freely up and down in the guide rails and that the shutter stops at its preset fully open and fully closed limits. If a remote control has been supplied with safety devices these should also be checked at this stage.

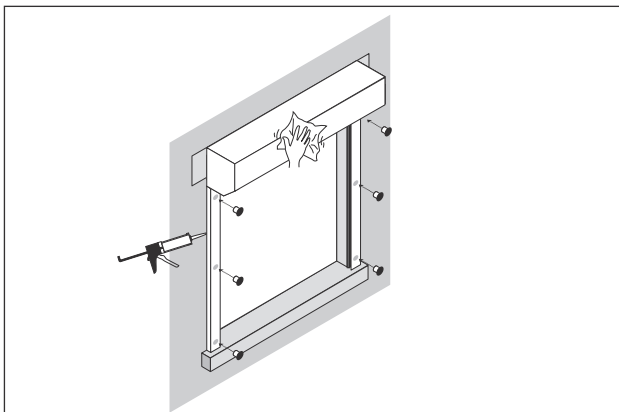

21 To complete the installation you should fit cover caps to the guide rails (if applicable), mastic around the edges of the shutter then give the shutter a final clean and tidy.

Upon completion of the installation the owner of the shutter must be trained how to operate the product safely paying special attention to the following points:

- **The shutter should only be operated when in view**
- **The operator should ensure there are no objects or persons in the opening before and during operation.**
- **The end user must read and follow the advice given in the operating and maintenance instructions.**
- **In the event of a malfunction the end user should follow the advice given in the operating and maintenance instructions and if applicable contact the installer.**

If applicable complete CE documentation and label the product to comply with the Machinery Directive.

8 Built-In-Shutters

Parts List

General Parts

- Shutter box shell (1 per shutter)
- Pair of guide rails (1 pair per shutter)
- Assembled curtain (1 per shutter)
- Axle assembly (1 per shutter)
- Installation instructions
- Operating & Maintenance instructions

Keys for bottom slat locks are packed in a bag which is taped to the bottom slat. (Spring Loaded Operation)

Accessories are packed in a separate box.

If applicable angle & packer are usually packed with the guide rails.

Operation Specific Parts

Rod Crank Operation

- Rod crank handle (1 per shutter)
- Rod crank handle clip (1 per shutter)

Electric operation

- Override handle (1 per shutter if manual override)
- Override handle clip (1 per shutter if manual override)

Electric control method (depends on method requested):

- Switch (with back box surface / flush)
- Key switch
- Remote control kit
- Group command
- Battery back up

8 Built-In Shutters Attaching box and guides to frame

Before you begin installing the shutter please ensure you have read pages 4–9.

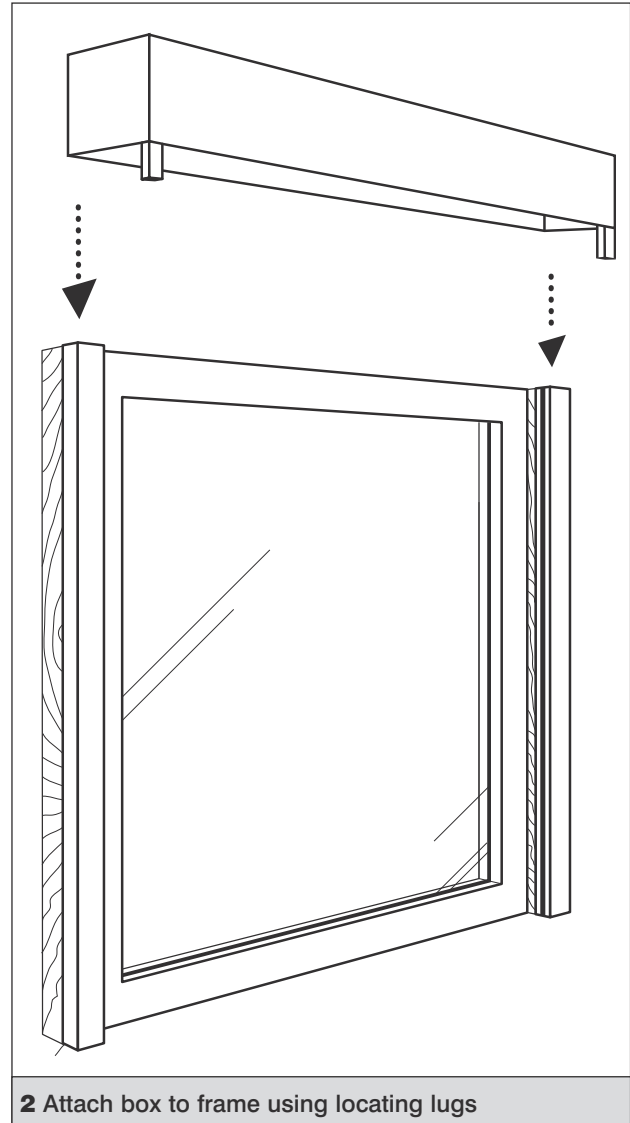
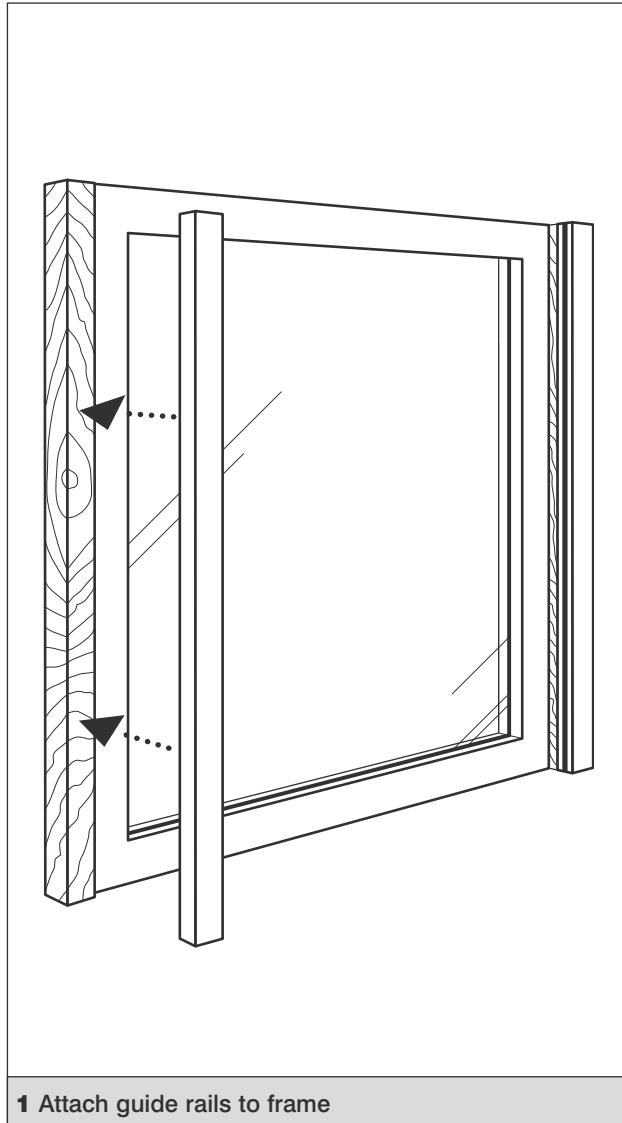

Important information:

- **When installed it is vital that the shutter box is not compressed by the surrounding wall.**
- **Once installed the box lid must remain accessible at all times and must not be covered up.**
- **To remove the box lid use a chisel or similar flat bladed tool.**

8.1 Rod Crank Operation Installation Instructions

Before you begin installing the shutter please ensure you have read pages 4–9.

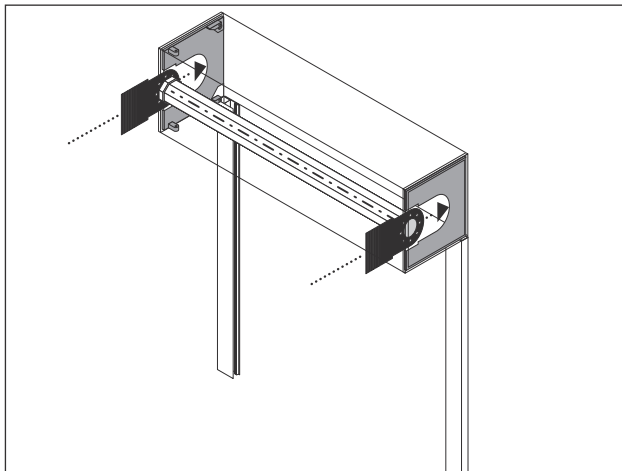

1 Slide the axle assembly into the shutter box as shown.

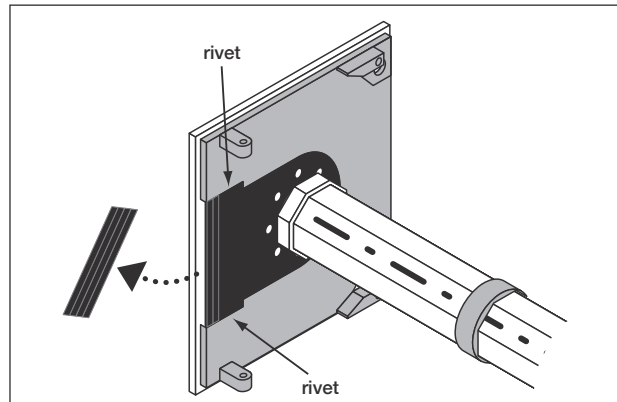

2 Remove the excess material from the axle supports as shown then rivet the black axle supports in place.

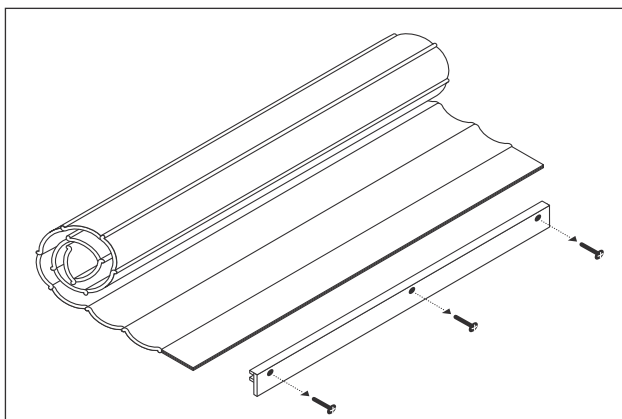

3 If a bottom slat handle has been fitted to the curtain it should be removed before you attempt to load the curtain into the shutter.

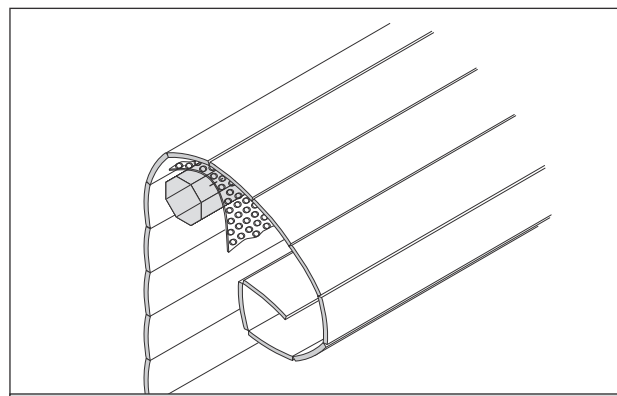

⚠ RISK OF MATERIAL DAMAGE!
4 Cover the axle with bubble wrap or a similar material to prevent the curtain from being damaged during the curtain loading process. Carefully load the curtain over the axle.

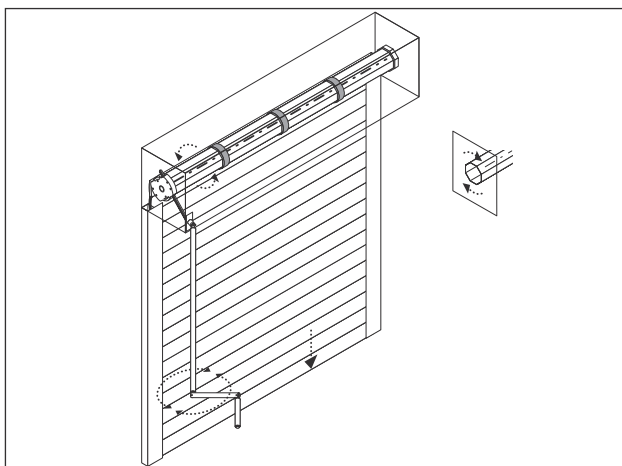

5 Wind the crank gear to the bottom stop then wind the axle back ½ a turn.

CURTAINS DIRECT TO AXLE NO. 10 X ½ PAN POZI – TYPE C

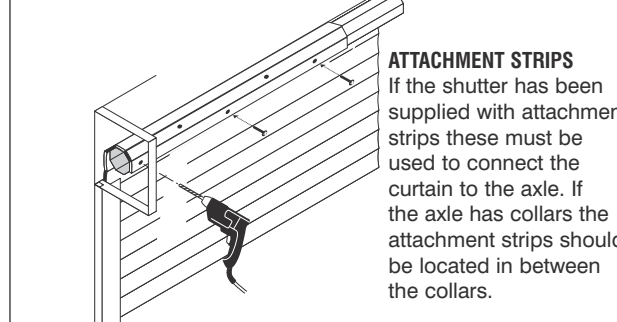

ATTACHMENT STRIPS
If the shutter has been supplied with attachment strips these must be used to connect the curtain to the axle. If the axle has collars the attachment strips should be located in between the collars.

6 Attach the top two slats of the curtain directly to the axle using the screws provided. The screws must be countersunk to prevent them damaging the slats which will coil on top.

8.1 Rod Crank Operation Installation Instructions (cont.)

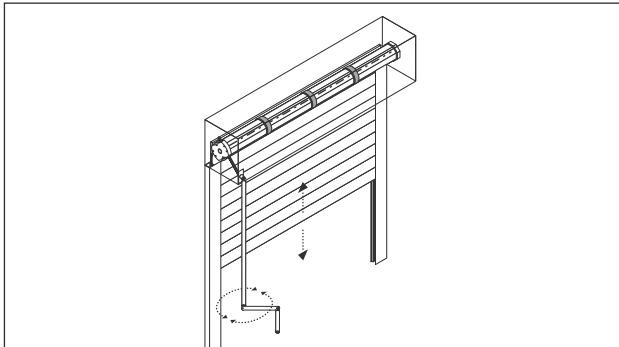

7 Insert the crank handle temporarily and slowly wind the handle to test the operation of the shutter. Test the shutter to ensure that the curtain locks correctly when the curtain closes fully. Please refer to the operating and maintenance instructions supplied for the correct method for operating and locking the shutter. Ensure that the shutter moves freely up and down in the guide rails.

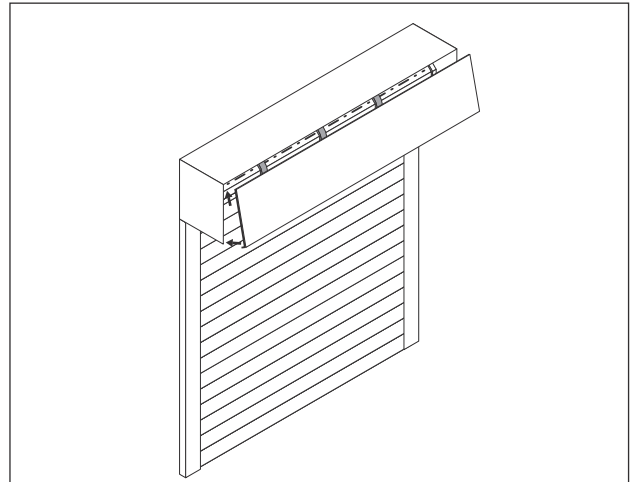

8 Fit the box lid to the shutter box.

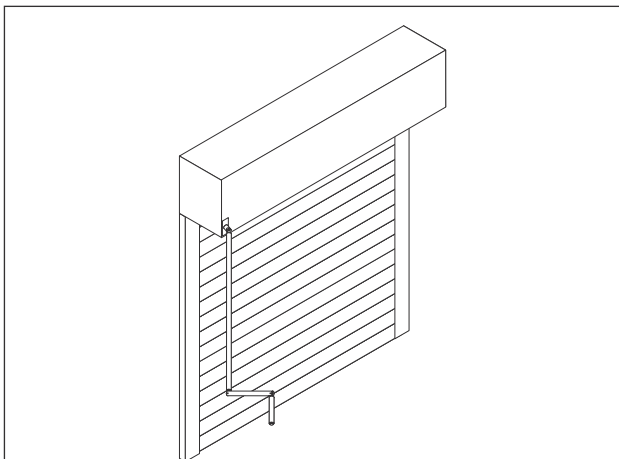

9 The crank handle should now be permanently attached to the shutter.

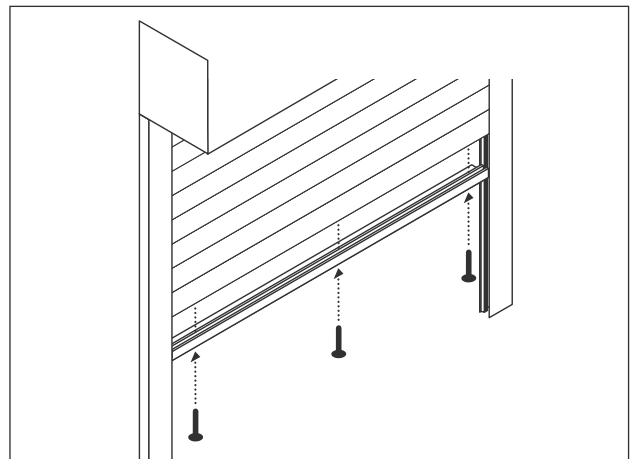

10 If a bottom slat handle has been supplied with this shutter it should now be fitted to the bottom slat.

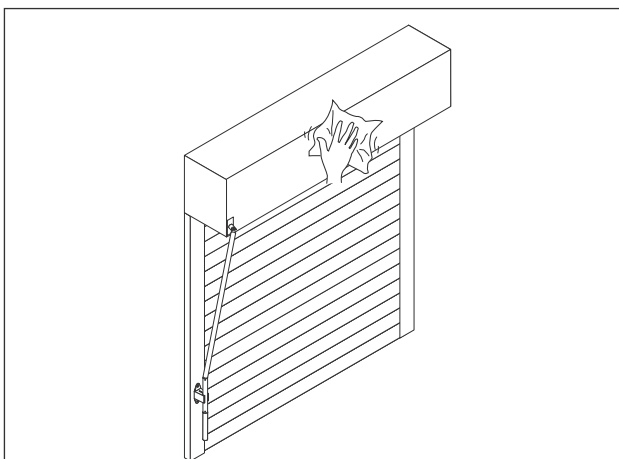

11 To complete the installation you should give the shutter a final clean and tidy.

Upon completion of the installation the owner of the shutter must be trained how to operate the product safely paying special attention to the following points:

- The shutter should only be operated when in view
- The operator should ensure there are no objects or persons in the opening before and during operation.
- The end user must read and follow the advice given in the operating and maintenance instructions.
- In the event of a malfunction the end user should follow the advice given in the operating and maintenance instructions and if applicable contact the installer.

8.2 Spring loaded Operation Installation Instructions

Before you begin installing the shutter please ensure you have read pages 4–9.

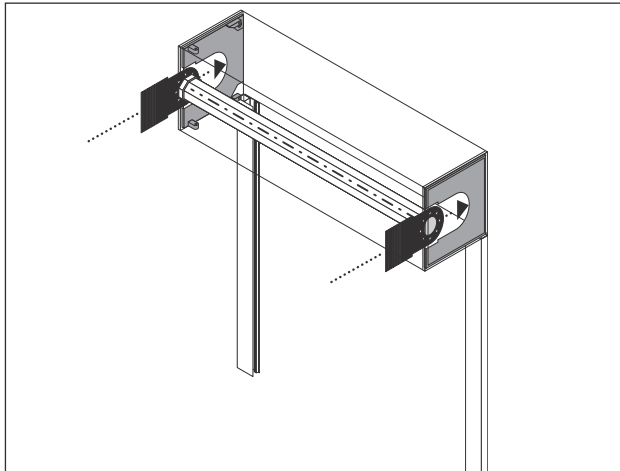

1 Slide the axle assembly into the shutter box as shown.

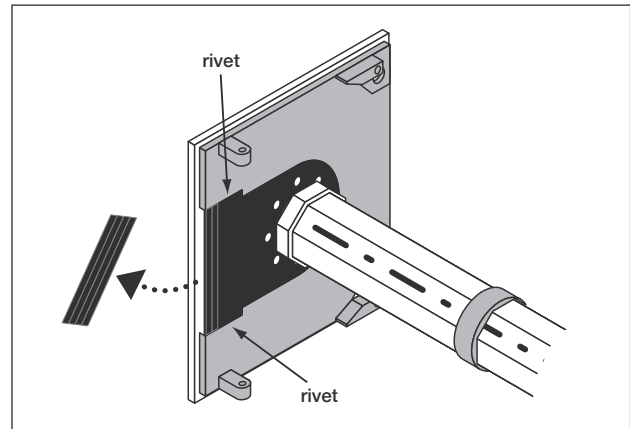

2 Remove the excess material from the axle supports as shown then rivet the black axle supports in place.

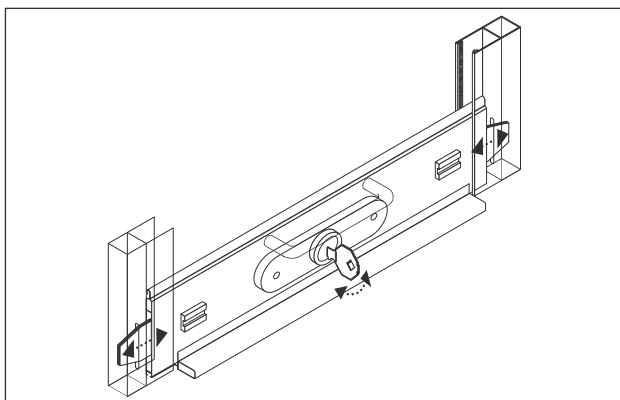

3 If shoot bolts or a lock have been supplied in the bottom slat you should remove the bottom slat from the curtain. Slide the bottom slat down into the guide rails and check that the lock bars in the bottom slat will locate into the prepared guide rail keeps. Enlarge the keeps if necessary.

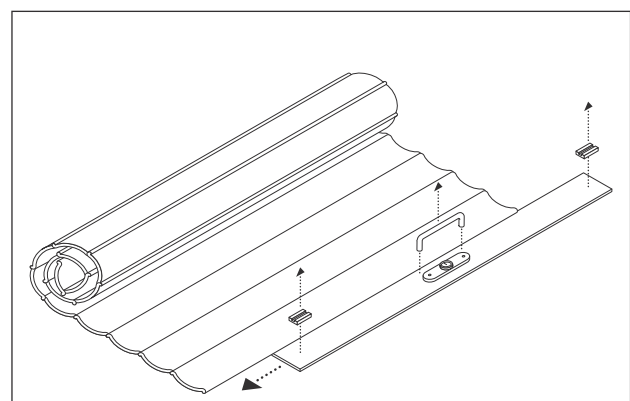

4 Remove the stops and handles which are attached to the bottom slat then attach the bottom slat to the curtain.

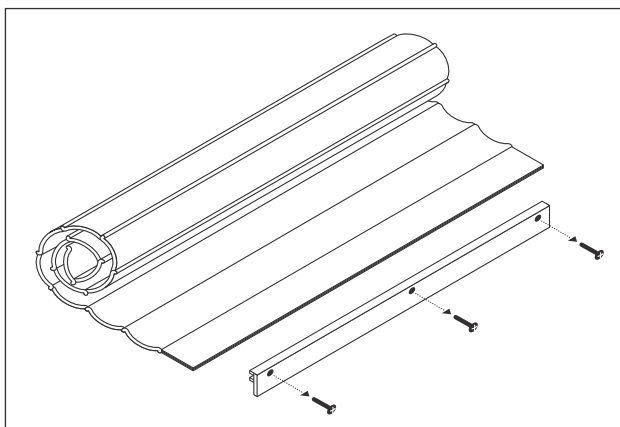

5 If a bottom slat handle has been fitted to the curtain it should be removed before you attempt to load the curtain into the shutter.

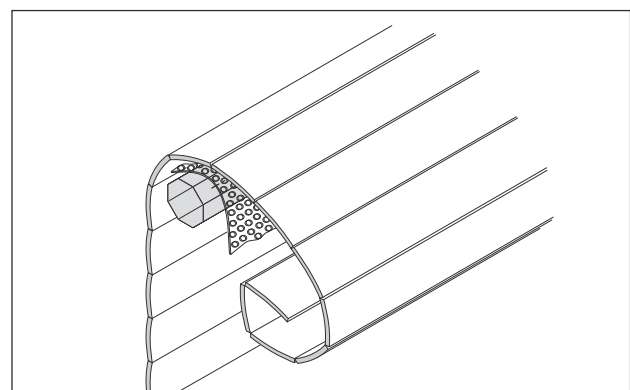

⚠ RISK OF MATERIAL DAMAGE!
6 Cover the axle with bubble wrap or a similar material to prevent the curtain from being damaged during the curtain loading process. Carefully load the curtain over the axle.

8.2 Spring Loaded Operation Installation Instructions (cont.)

CURTAINS DIRECT TO AXLE NO. 10 X 1/2 PAN POZI – TYPE C

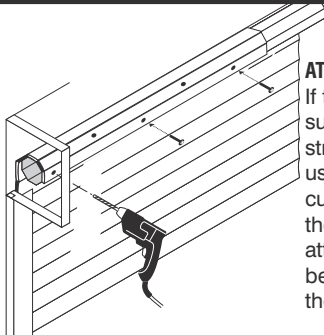

ATTACHMENT STRIPS
If the shutter has been supplied with attachment strips these must be used to connect the curtain to the axle. If the axle has collars the attachment strips should be located in between the collars.

7 Attach the top two slats of the curtain directly to the axle using the screws provided. The screws must be countersunk to prevent them damaging the slats which will coil on top.

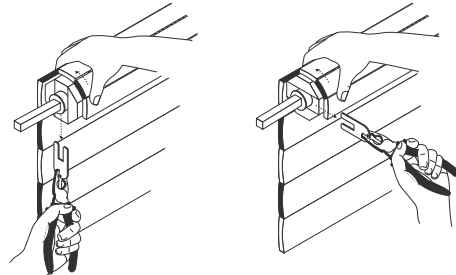

STOP **RISK OF PERSONAL INJURY!**
8 Turn the axle in the down direction and carefully remove the pin. Please note there may be tension on the spring, which will cause the axle to turn. If the shutter contains a second anti-fall back spring (double spring) only one of the springs should be supplied with a pin. The shutter should be installed in the same way as a standard spring loaded shutter.

TIP - Lock the bottom slat to prevent the curtain from lifting and the axle from turning

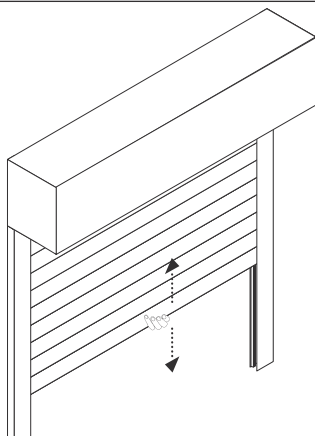

RISK OF MATERIAL DAMAGE!
9 Test the operation keeping hold of the bottom slat at all times.

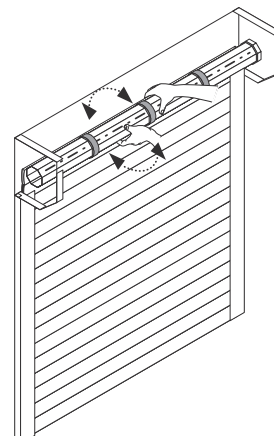

10 If required adjust the tension in the spring.
RISK OF MATERIAL DAMAGE!
STOP For safety reasons it is advisable for the tension to be adjusted by two people.

Method 1:
Lift the curtain to the top so that it coils around the axle. Place cardboard between the lock and the curtain to prevent the lock from damaging the curtain. Now allow the bottom slat to come out of the top of the guides so that you can rotate the coil to add to or release the tension in the spring.
To add tension to the spring turn the axle in the down direction.
To release tension from the spring turn the axle in the up direction.
Once adjusted feed the curtain back into the guide rails and test the operation. Repeat this process until the spring contains the correct amount of tension.

Method 2:
Lower the curtain to the floor. Turn the axle forward and insert the pin in the end of the spring to lock the axle (reverse of step 14). Detach the curtain from the axle. Carefully remove the pin then add or remove tension from the spring as appropriate.
To add tension to the spring turn the axle in the down direction.
To release tension from the spring turn the axle in the up direction.
Once adjusted replace the pin then continue as step 13.

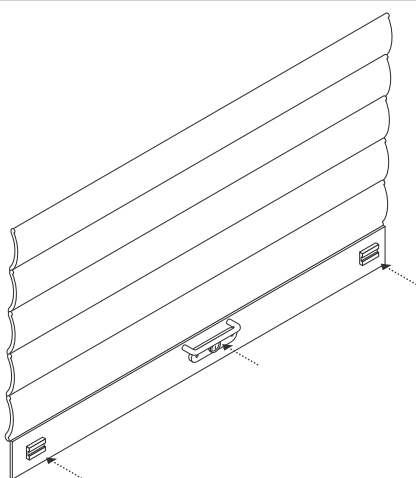

11 Attach the stops and handles removed earlier.

8.2 Spring loaded Operation Installation Instructions (cont.)

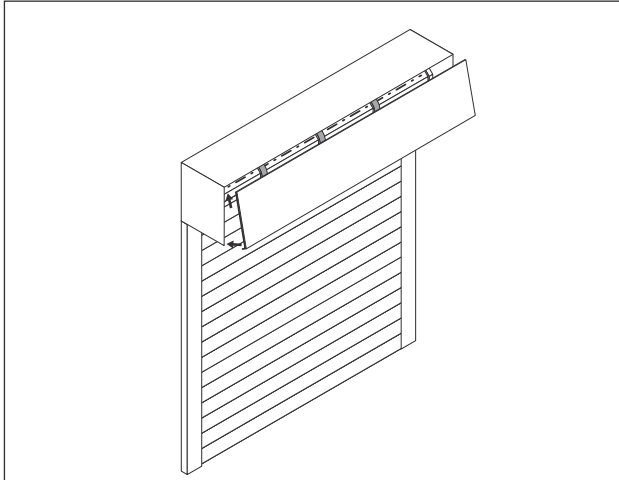

12 Fit the box lid to the shutter box.

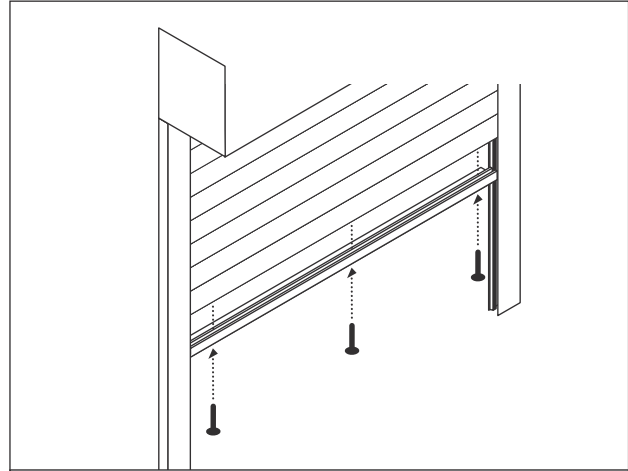

13 If applicable attach the bottom slat handle to the bottom slat.

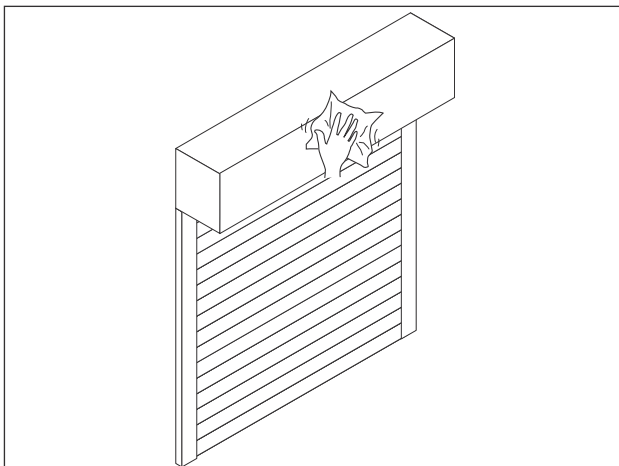

14 To complete the installation you should give the shutter a final clean and tidy.

Upon completion of the installation the owner of the shutter must be trained how to operate the product safely paying special attention to the following points:

- **The shutter should only be operated when in view**
- **The operator should ensure there are no objects or persons in the opening before and during operation.**
- **The end user must read and follow the advice given in the operating and maintenance instructions.**
- **In the event of a malfunction the end user should follow the advice given in the operating and maintenance instructions and if applicable contact the installer.**

8.3 Electric Operation Installation Instructions

Before you begin installing the shutter please ensure you have read pages 4–9.

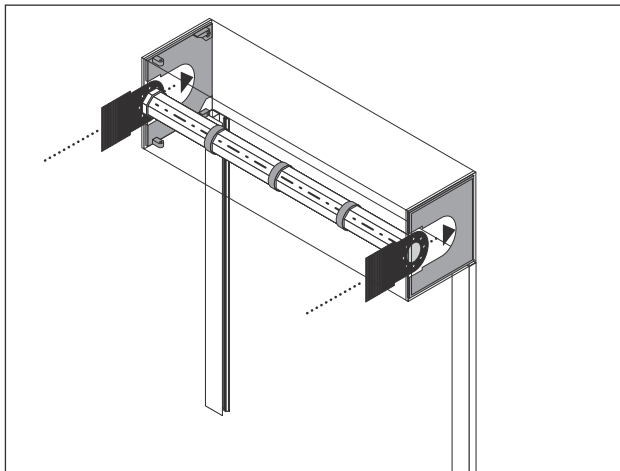

1 Slide the axle assembly into the shutter box as shown.

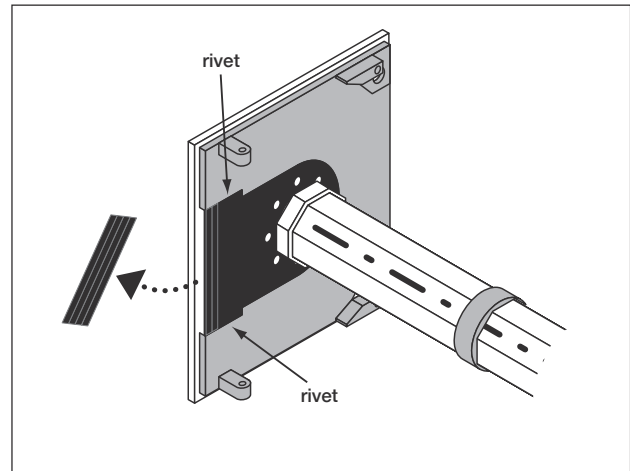

2 Remove the excess material from the axle supports as shown then rivet the black axle supports in place.

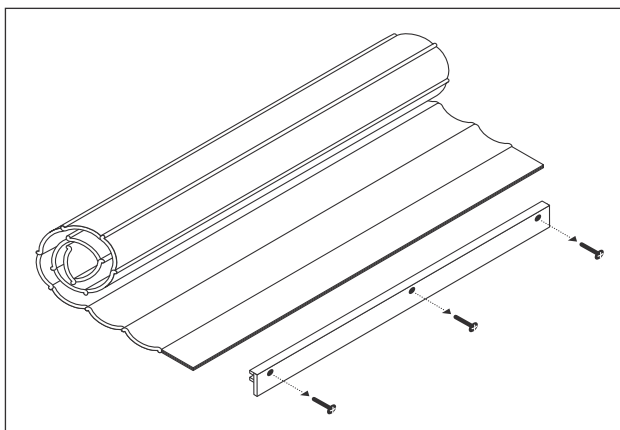

3 If a bottom slat handle has been fitted to the curtain it should be removed before you attempt to load the curtain into the shutter.

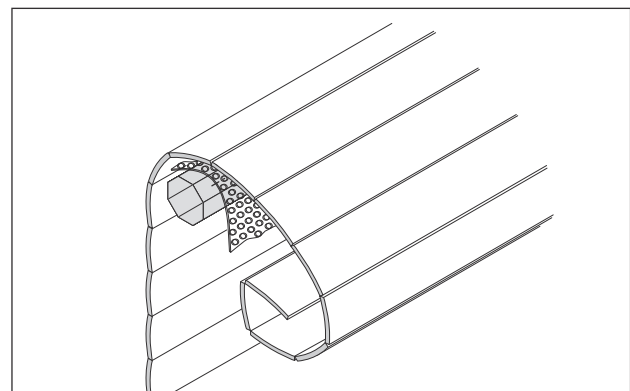

⚠ RISK OF MATERIAL DAMAGE!
4 Cover the axle with bubble wrap or a similar material to prevent the curtain from being damaged during the curtain loading process. Carefully load the curtain over the axle.

Please note locking springs will not be attached at this stage, this drawing is for illustrative purposes only

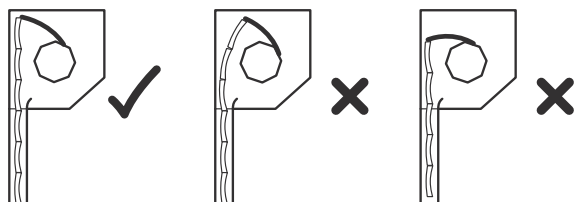

5 Check the curtain height. When pushed towards the back of the shutter box the curtain should finish just under the box top. If the curtain is too tall then slats should be removed to obtain the correct height. If the curtain finishes more than one slat beneath the shutter box top then the curtain is too short and the height must be increased in order for the shutter to lock correctly when fully down.

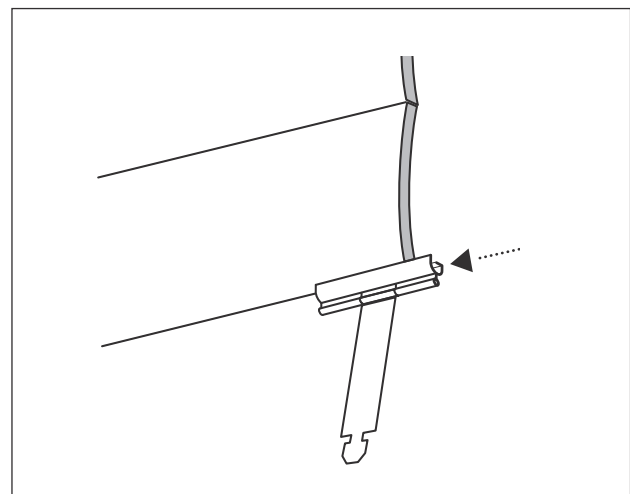

6 Load the locking springs onto the curtain.

8.3 Electric Operation Installation Instructions (cont.)

LOCKING SPRINGS NO. 8 X 1/4 PAN FLANGE POZI – TYPE C

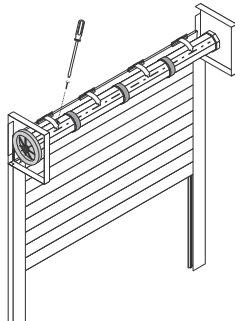

ATTACHMENT STRIPS

If the shutter has been supplied with attachment strips these must be used to connect the curtain to the axle. If the axle has collars the attachment strips should be located in between the collars.

7 Please note if this shutter has been supplied with an anti-fall back spring then the spring should be tensioned before you attach the curtain to the axle (see section 13.2) Attach the locking springs / attachment straps to the axle using the screws supplied.

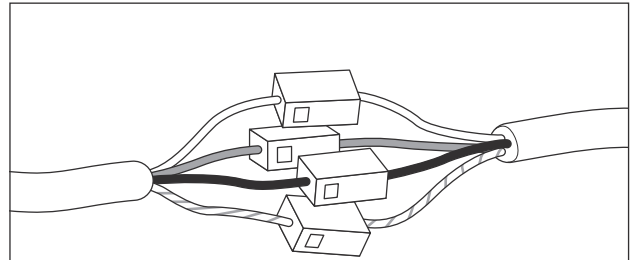

8 It is recommended that you use a test lead to set the motor limits or if a remote control is being supplied set the remote control into commissioning mode (see section 11.2). If a remote control is not being used or if you do not have a motor test lead the motor should now be wired to the switch supplied (see section 11).

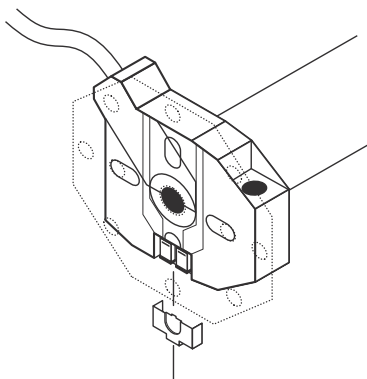

9 Set the motor limits (see section 12)

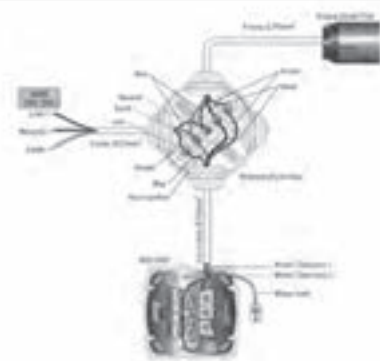

10 Wire the control method supplied to the shutter (see section 11 for further details). If an anti-drop brake has been supplied with a limit switch (wire attached to the anti-drop brake) this will also require wiring in at this stage (see section 13.1).

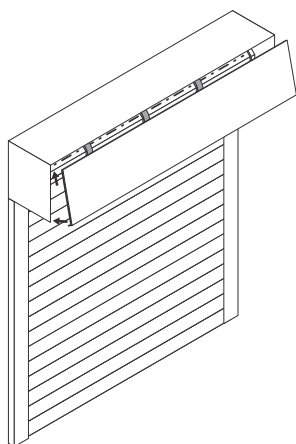

11 Fit the box lid to the shutter box.

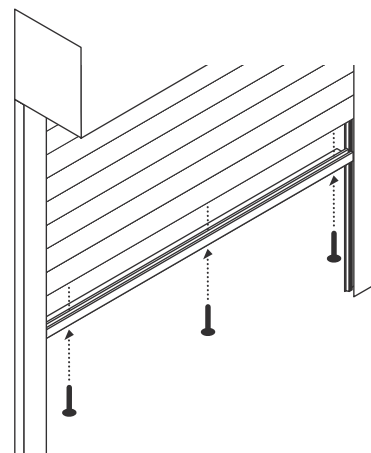

12 If applicable attach the bottom slat handle to the bottom slat.

8.3 Electric Operation Installation Instructions (cont.)

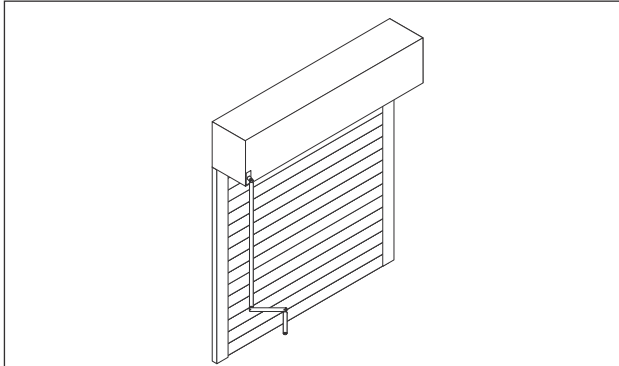

13 If applicable attach the override handle / rigid eye / drop eye to the shutter and test the manual override facility. Once you have identified which direction will open the shutter attach the label supplied to the override handle showing the end user which direction to wind the manual override to operate the shutter.

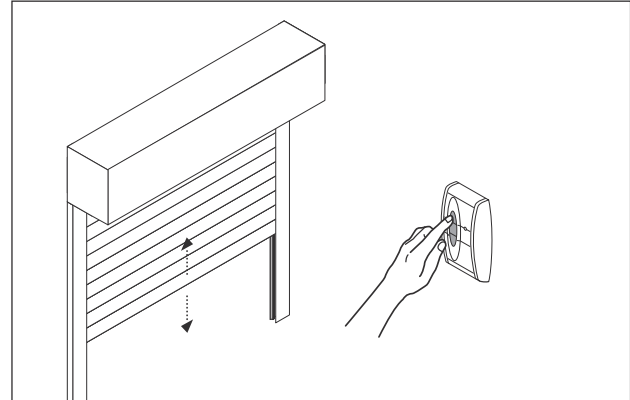

14 Test the operation of the shutter to ensure that the shutter moves freely up and down in the guide rails and that the shutter stops at its preset fully open and fully closed limits. If a remote control has been supplied with safety devices these should also be checked at this stage.

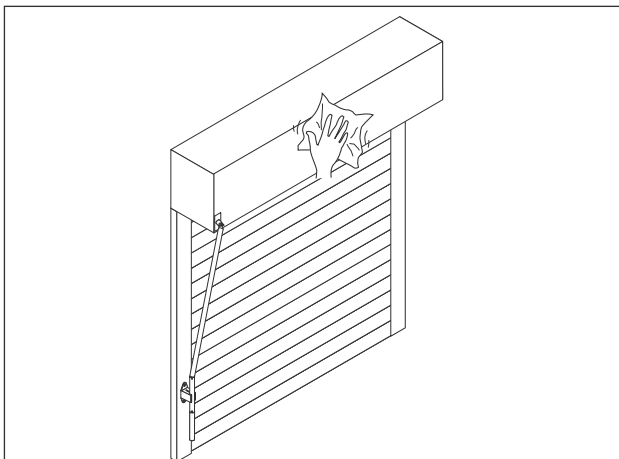

15 To complete the installation you should give the shutter a final clean and tidy.

Upon completion of the installation the owner of the shutter must be trained how to operate the product safely paying special attention to the following points:

- **The shutter should only be operated when in view**
- **The operator should ensure there are no objects or persons in the opening before and during operation.**
- **The end user must read and follow the advice given in the operating and maintenance instructions.**
- **In the event of a malfunction the end user should follow the advice given in the operating and maintenance instructions and if applicable contact the installer.**

If applicable complete CE documentation and label the product to comply with the Machinery Directive.

9 Built-On Security Shutter

9 Insurance / Police Approved Security Shutter Parts List

General Parts

- Assembled shutter box (1 per shutter)
- Pair of guide rails (1 pair per shutter)
- Assembled curtain (depending on the shutter size may be supplied in sections)
- Installation instructions
- Operating & Maintenance instructions

Operation Specific Parts

- Override handle (1 per shutter if manual override)
- Override handle clip (1 per shutter if manual override)
- Electric control method (depends on method requested):
- Switch (with back box surface / flush)
- Key switch
- Remote control kit
- Group command
- Battery back up

Accessories are packed in a separate box.

If applicable angle & packer are usually packed with the guide rails.

Guide to correct guide rail orientation

Certain guide rails have an internal and external face, due to their extrusion profile. These guide rails must be installed the correct way round. Please check the guide rails you have been supplied before you begin installing the shutter.

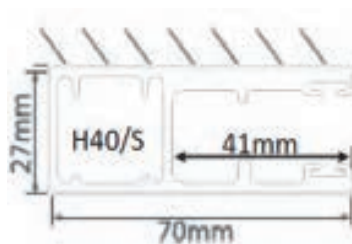

On the base of the guide rails there will be steel reinforcement plates which are part of the insurance approved specification. The type supplied will be dependant on whether the guide rails are face or reveal fitted.

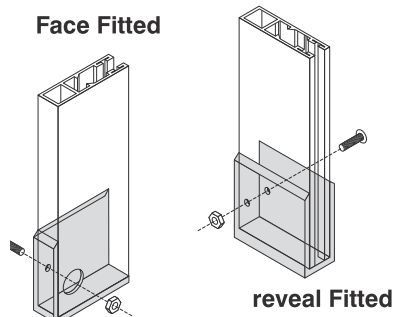

9 Built-On Security Shutter Installation Instructions

Before you begin installing the shutter please ensure you have read pages 4–9. **The LPCB certification awarded to this product is subject to it being installed in accordance with the requirements set out in the following instructions Only then can the LPCB badge supplied be applied**

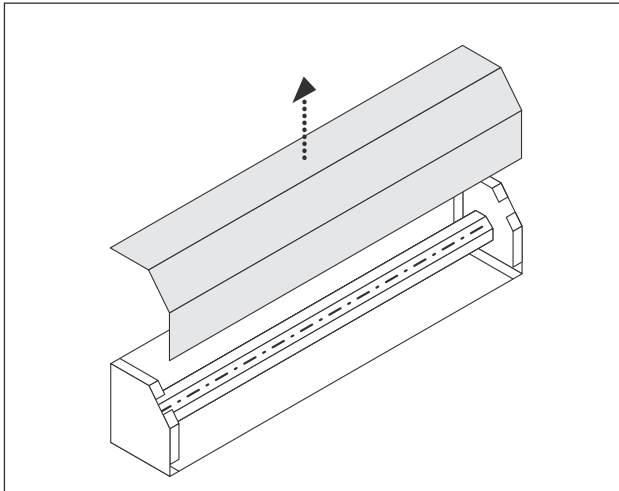

1 Remove the lid from the shutter box

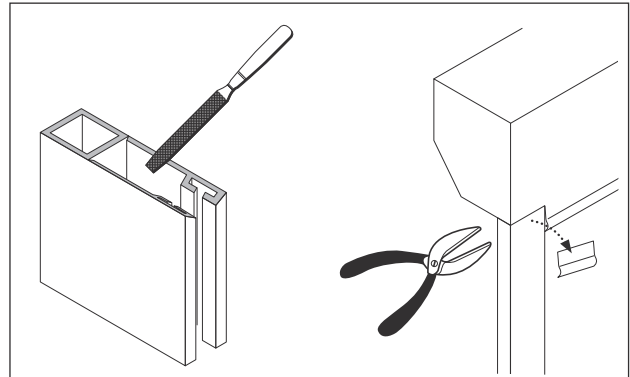

2 File the top of the guides at an angle to create the optimum lead in for the curtain. Guide insert should also be trimmed to suit the filed guide tops. If the shutter is being face fitted remove the lip from the box back which overlaps the guide rails.

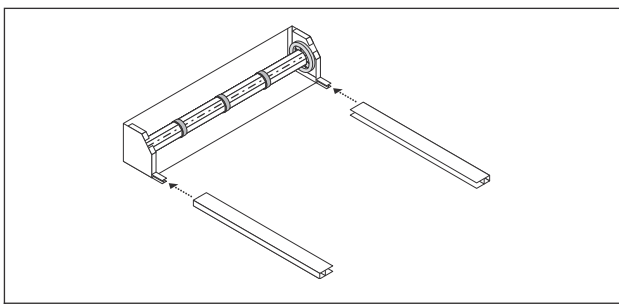

3 Carefully locate the guide rails onto the box lugs ensuring that on face fit guides the 13mm holes are on the outside. The guide rails should have a protective steel guide foot located at the base of each guide rail. When moving the shutter as a complete unit you should take care to prevent the lugs being snapped off the box ends by the leverage available from the guide rails. If the shutter is too large to be lifted up as a complete unit you should offer up, locate and fix the individual guide rails then the shutter box.

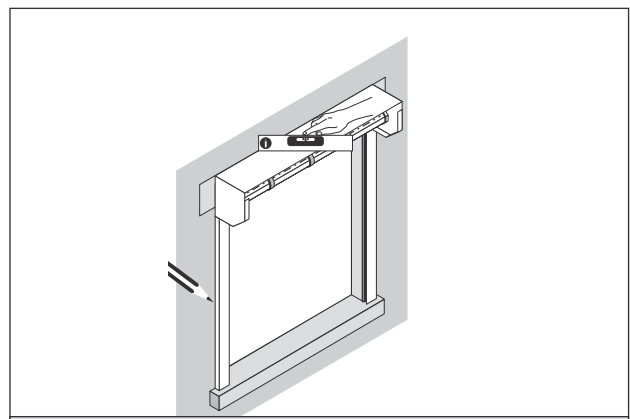

4 Offer the shutter to the opening and centralise, ensuring the top of the shutter box is horizontal and that both guide rails are vertical. Mark the guide location.

EXTERNAL SHUTTERS ONLY

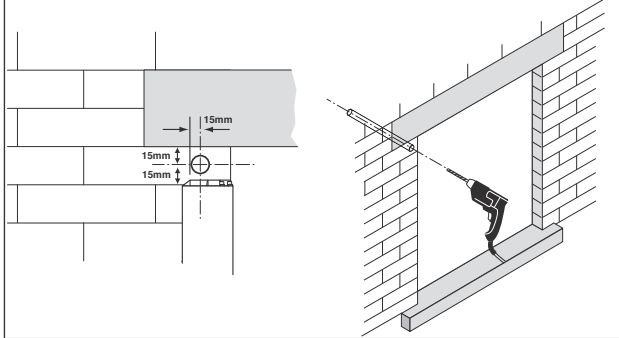

5 If applicable mark and drill the override hole ensuring the hole is drilled at the correct angle (see step 6). Drill a 10mm pilot hole followed by a 22mm hole
Tip – hold a block of wood against plaster to reduce damage caused by the drilling process

EXTERNAL SHUTTERS ONLY

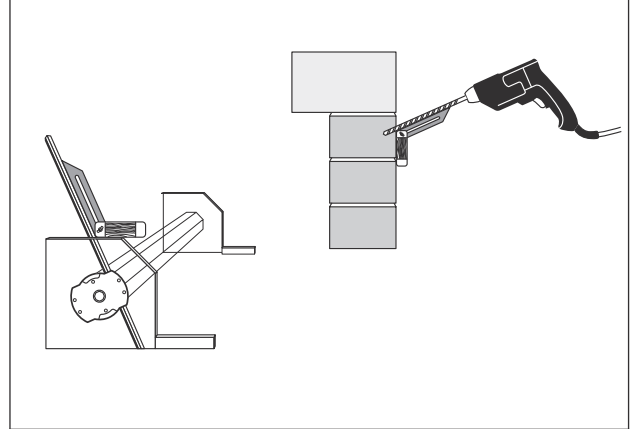

6 If a manual override has been supplied and if applicable determine the angle of the override hole.

9 Built-On Security Shutter Installation Instructions (cont.)

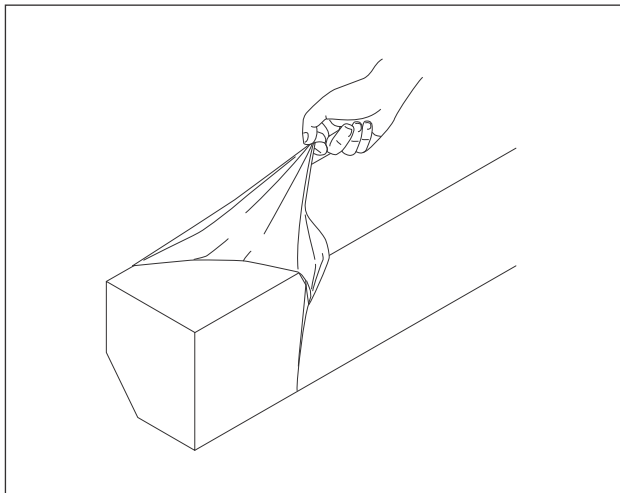

7 Remove film from box top

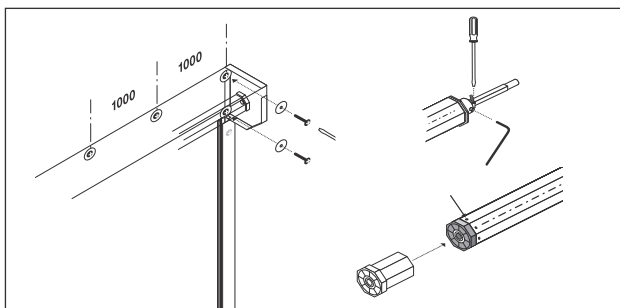

9 Fit the shutter box using the recommended spacings. The minimum required fasteners are No.12 x 21/2" screws and plugs for masonry and M8 fasteners with 10mm engagement for steel. A minimum of 2 fixings per end plate are required. Once the shutter box has been installed check the dummy end making sure that it is securely located within the axle. If the dummy end is a shaft bolt design make sure that the centre shaft is fixed in place so that it can not slide back into the axle.

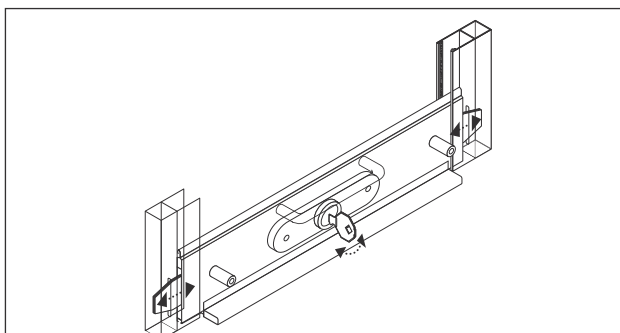

10 If a lock has been supplied in the bottom slat you should remove the bottom slat from the curtain. Slide the bottom slat down into the guide rails and check that the lock bars in the bottom slat will locate into the prepared guide rail keeps. Enlarge the keeps if necessary.

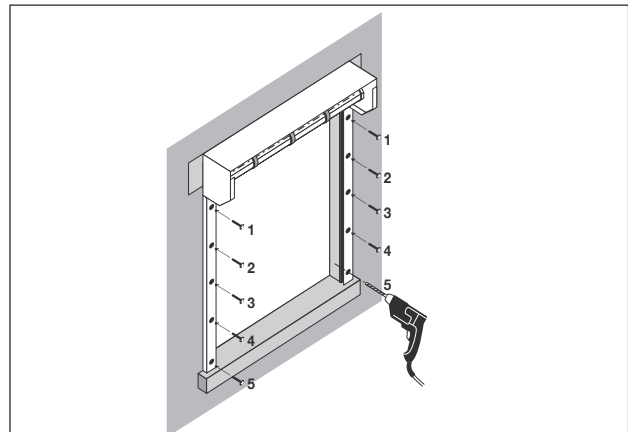

8 Starting with the top holes, fix the guide rails ensuring that the guide rails are vertical and that the shutter box is horizontal. **Each guide rail must have a minimum of 5 fixings** (irrespective of size). The minimum required fasteners are No.12 x 21/2" screws and plugs for masonry and M8 fasteners with 10mm engagement for steel. Note that for fixing into masonry the fasteners must be at least 50mm clear of the reveal (to prevent breakaway from the corner) and for steel 20mm. Once fastened the heads of all fixings must be spoilt.

Alternative method for face fix installation:

To offer improved security the fasteners can be located inside the main channel of the guide rail instead of the box section so that when the curtain is lowered it covers the fasteners. To achieve this you should drill a minimum of 5 x 13mm holes on the exposed face of the guide rail and corresponding 7mm holes on the face, which will be fastened to the wall. Use a sharp knife to reduce the depth of the 13mm cover caps (to prevent them from catching the curtain).

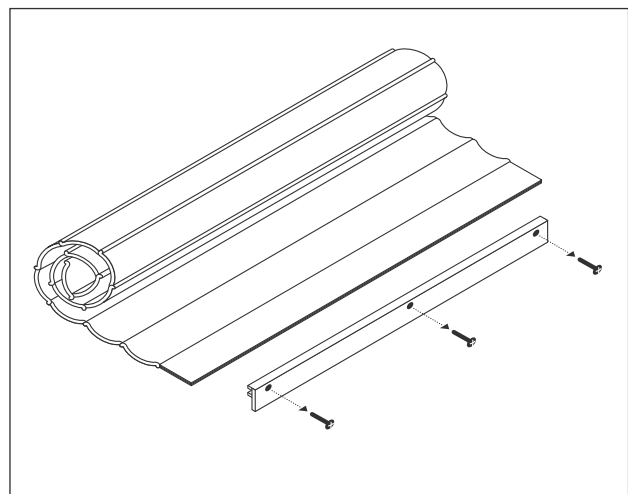

11 Attach bottom slat to curtain

9 Built-On Security Shutter Installation Instructions (cont.)

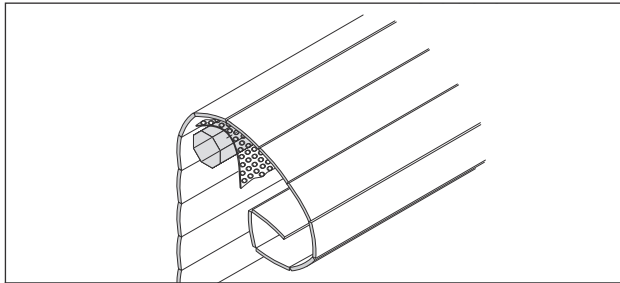

⚠ RISK OF MATERIAL DAMAGE!
12 Cover the axle with bubble wrap or a similar material to prevent the curtain from being damaged during the curtain loading process. Carefully load the curtain over the axle. If the shutter has been supplied with bullet locks attached to the guide rails you will now need to prepare the curtain for the bullet lock pins. When the curtain is in the fully closed position drill a 13mm hole through each housing through the curtain. Check that the bullet lock pins will lock and release.

CURTAINS DIRECT TO AXLE NO. 10 X 1/2 PAN POZI – TYPE C

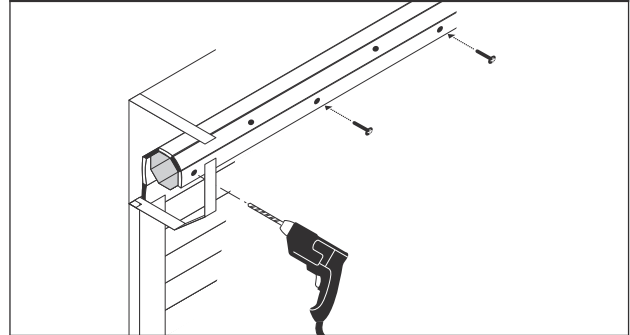

13 Attach the curtain directly to the axle through the top two slats using the screws provided. Do not use locking springs. Screw heads must be countersunk to prevent damage to the curtain.

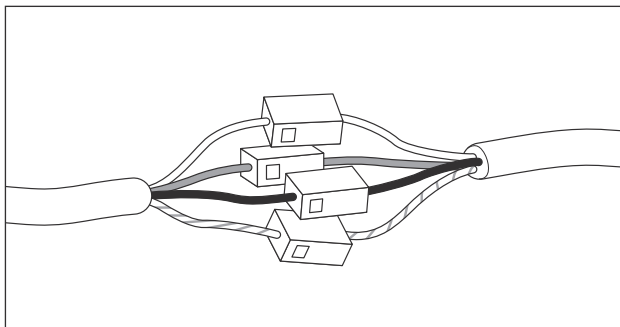

14 It is recommended that you use a test lead to set the motor limits or if a remote control is being supplied set the remote control into commissioning mode (see section 11.2). If a remote control is not being used or if you do not have a motor test lead the motor should now be wired to the switch supplied (see section 11).

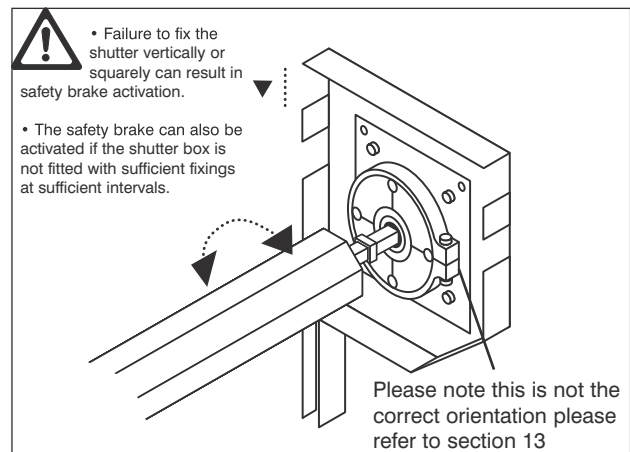

15 If applicable check anti-fall back device (see section 13.1)

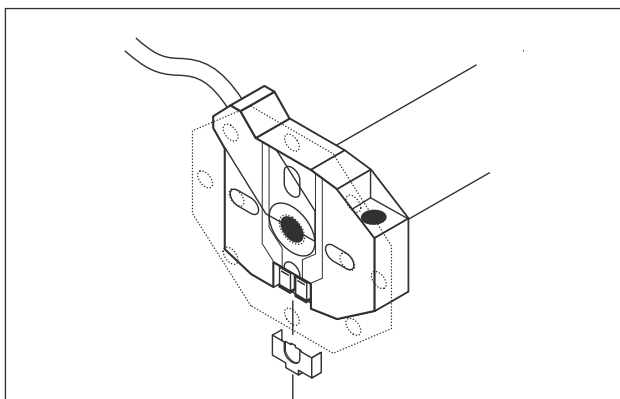

16 Set the motor limits (see section 12). Please note that the lower motor limit should be set at a point where it is impossible to raise the curtain when the bottom lock is not engaged.

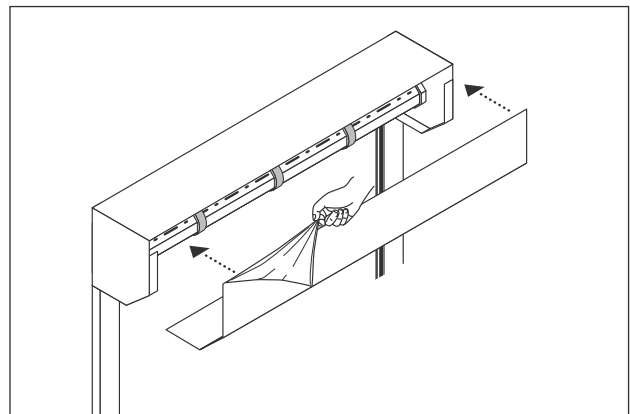

17 Remove the protective film from the box lid then fit the box lid to the shutter box. If the shutter is externally fitted the box lid should be fastened using appropriately coloured 4mm rivets.

9 Built-On Security Shutter Installation Instructions (cont.)

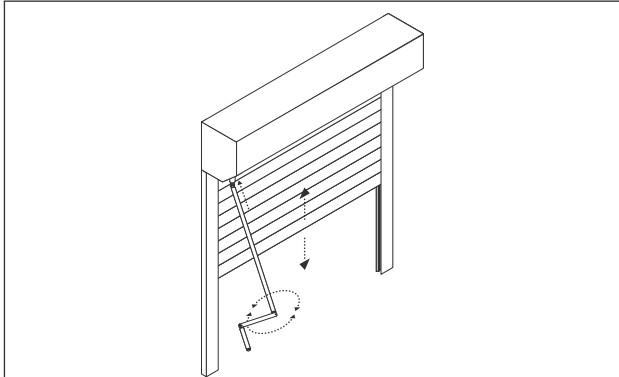

18 If applicable attach the override handle / rigid eye / drop eye to the shutter and test the manual override facility. Once you have identified which direction will open the shutter attach the label supplied to the override handle showing the end user which direction to wind the manual override to operate the shutter.

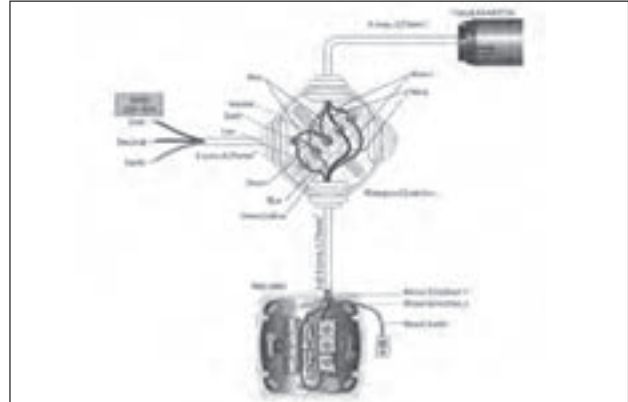

19 Wire the control method supplied to the shutter (see section 11 for further details). If an anti-drop brake has been supplied with a limit switch (wire attached to the anti-drop brake) this will also require wiring in at this stage (see section 13.1).

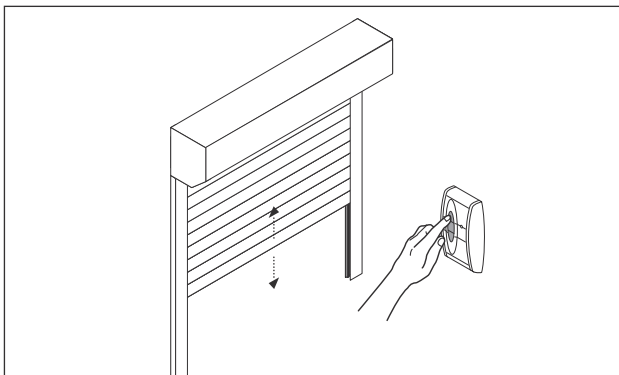

20 Test the operation of the shutter to ensure that the shutter moves freely up and down in the guide rails and that the shutter stops at its preset fully open and fully closed limits. If a remote control has been supplied with safety devices these should also be checked at this stage. Also ensure that the locks engage and disengage satisfactorily.

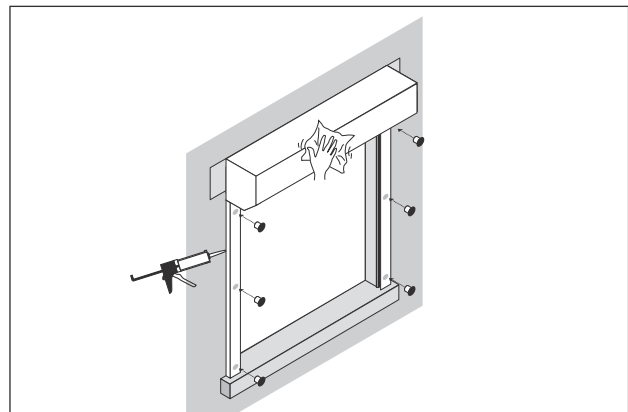

21 To complete the installation you should fit cover caps to the guide rails (if applicable), mastic around the edges of the shutter then give the shutter a final clean and tidy.

Upon completion of the installation the owner of the shutter must be trained how to operate the product safely paying special attention to the following points:

- **The shutter should only be operated when in view**
- **The operator should ensure there are no objects or persons in the opening before and during operation.**
- **The end user must read and follow the advice given in the operating and maintenance instructions.**
- **In the event of a malfunction the end user should follow the advice given in the operating and maintenance instructions and if applicable contact the installer.**

If applicable complete CE documentation and label the product to comply with the Machinery Directive.

10 Traditional Commercial Shutters

Parts List

General Parts

- Assembled axle assembly (1 per shutter)
- Pair of flag assemblies (angle, guides, and endplates)
- Assembled curtain (depending on the shutter size may be supplied in sections)
- Steel hood
- Installation Instructions
- Operating and maintenance instructions

Operation specific parts

- Steel stops and bolts (4 per shutter, attached to guide)

Keys for bottom slat locks are packed in a bag which is taped to the bottom slat.

Accessories are packed in a separate box.

If applicable angle & packer are usually packed with the guide rails.

10.1 Spring Loaded Operation Installation Instructions

Before you begin installing the shutter please ensure you have read pages 4–9.

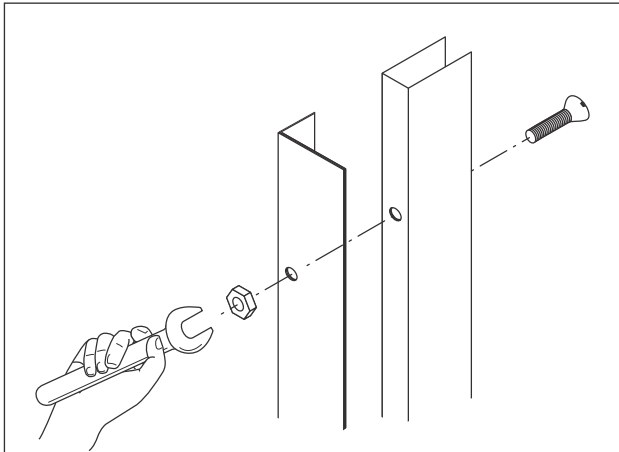

1 The channels are supplied with the angles attached these must be removed.

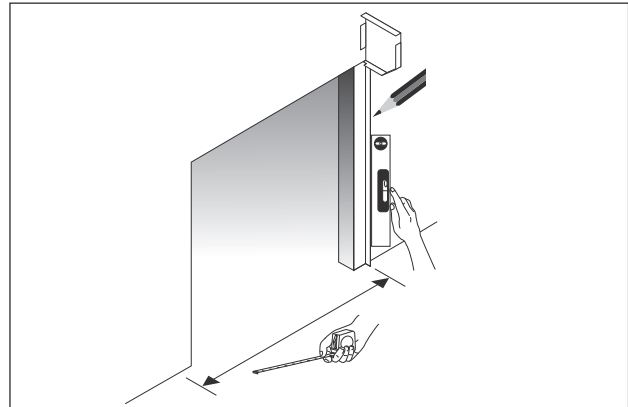

2 Measure the opening to determine the location of the first length of angle. If the floor is sloping you must fit the higher side first. Fix the angle to the wall.

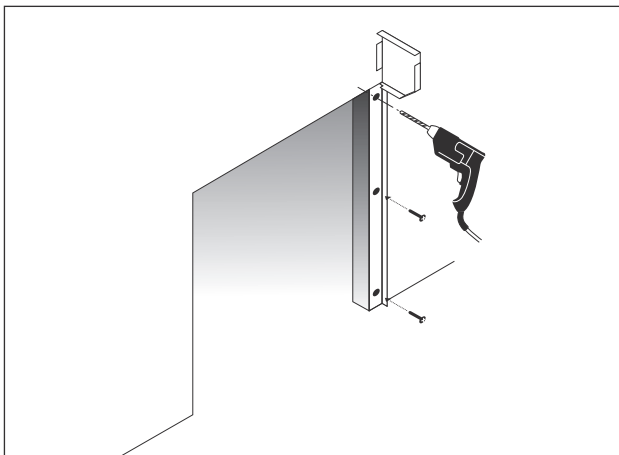

3 Offer angle up and fix to wall ensuring vertical (use all fixing holes provided)

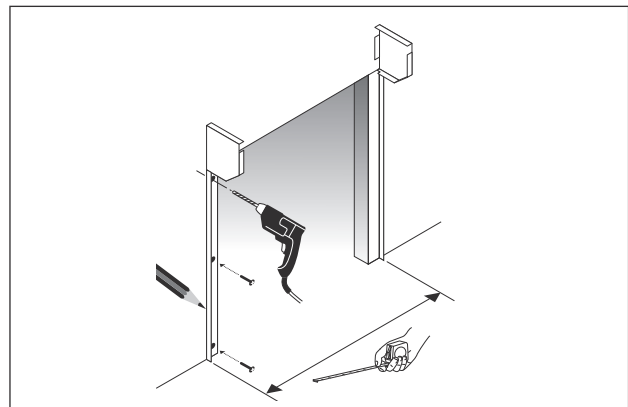

4 Measure from the first angle to determine the position of the second angle ensuring that the angles are vertical and also that the tops of the end plates are level. Fix the angle to the wall.

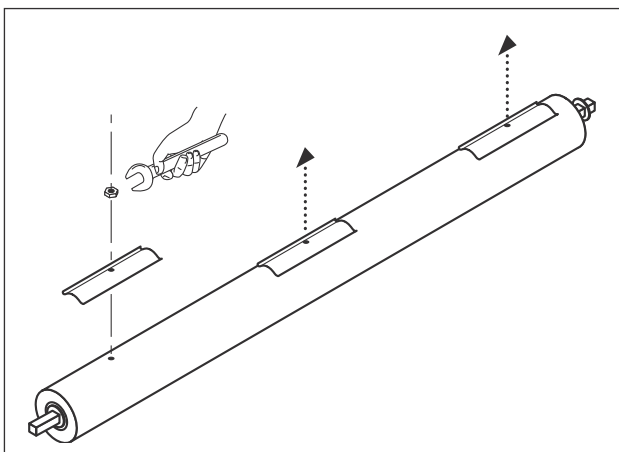

5 Remove the attachment strips from the axle.

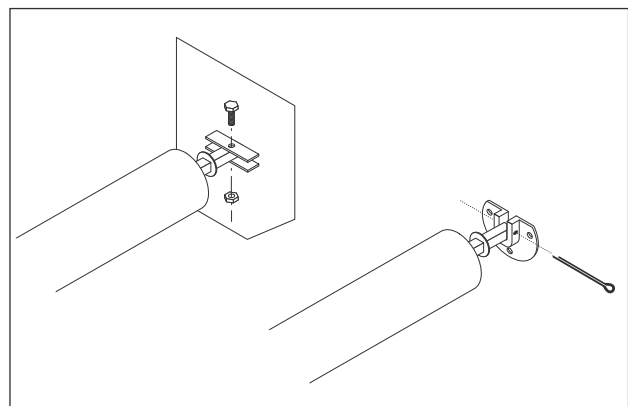

6 Attach the axle to the end plates using the fixings provided. You must ensure that the bolts located along the length of the axle for curtain attachment will be available for step 11.

10.1 Spring Loaded Operation Installation Instructions (cont.)

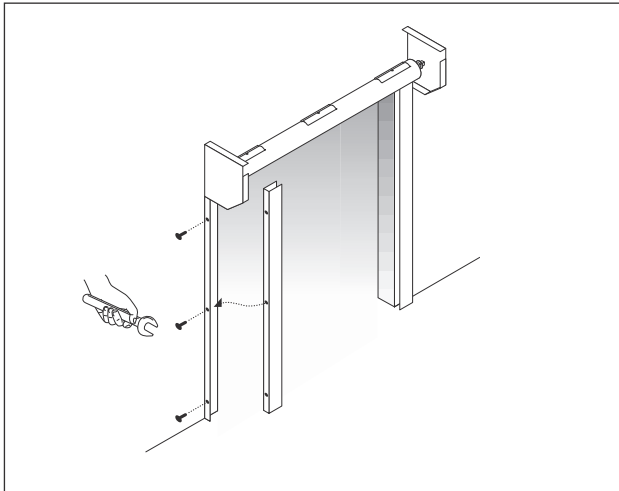

7 Attach the channels to the angles.

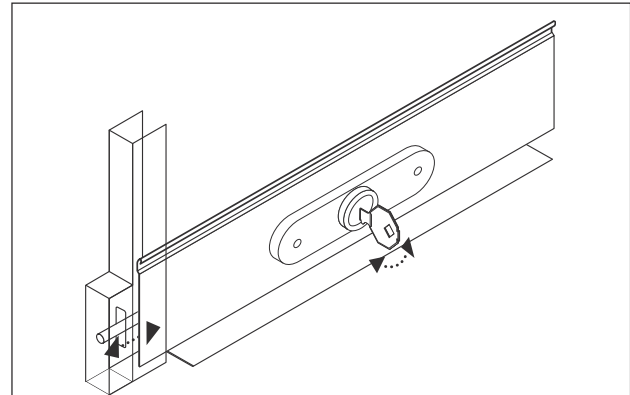

8. If a lock has been supplied in the bottom slat you should remove the bottom slat from the curtain. Slide the bottom slat down into the guide rails and check that the lock bars in the bottom slat will locate into the prepared guide rail keeps. Enlarge the keeps if necessary.

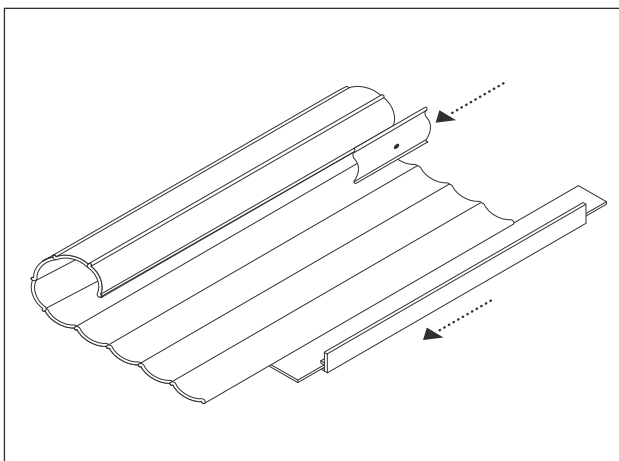

9 Attach the bottom slat and the attachment strips to the curtain.

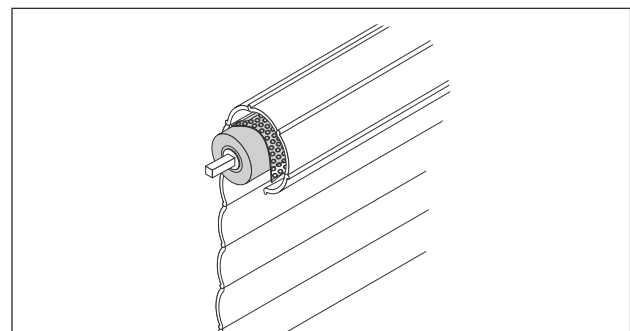

⚠ RISK OF MATERIAL DAMAGE!
10 Cover the axle with bubble wrap or a similar material to prevent the curtain from being damaged during the curtain loading process. Carefully load the curtain over the axle.

💡 TIP – Place blocks on the floor under the bottom slat to raise the curtain off the ground. This will make it easier to attach the curtain to the axle in the next step.

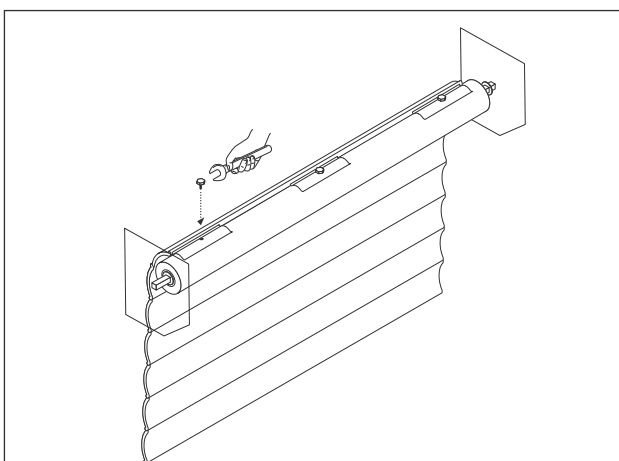

11 Attach the curtain to the axle using the attachment strips provided.

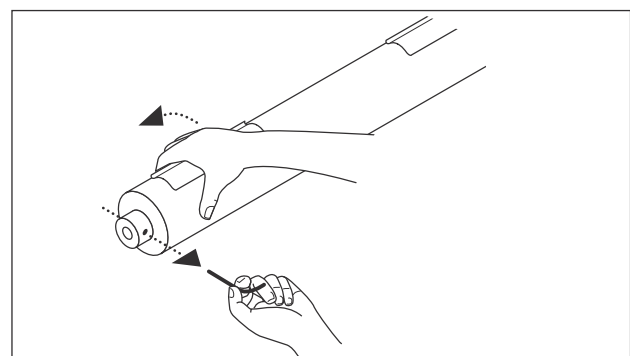

⚠ RISK OF PERSONAL INJURY!
12 Turn the axle in the down direction and carefully remove the pin. Please note there maybe tension on the spring, which will cause the axle to turn.

💡 TIP - Lock the bottom slat to prevent the curtain from lifting and the axle from turning

10.1 Spring Loaded Operation Installation Instructions (cont.)

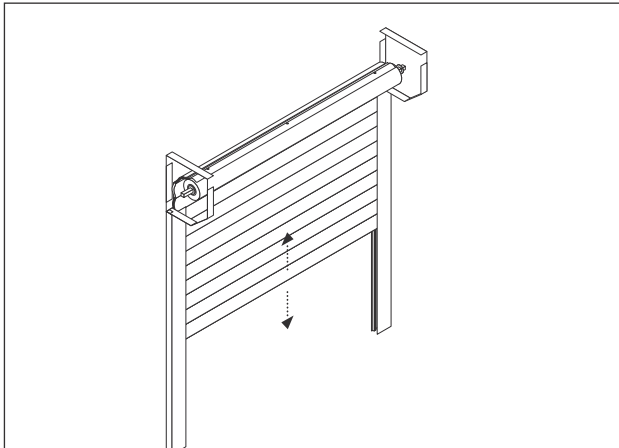

⚠ RISK OF MATERIAL DAMAGE!
13 Test the operation keeping hold of the bottom slat at all times.

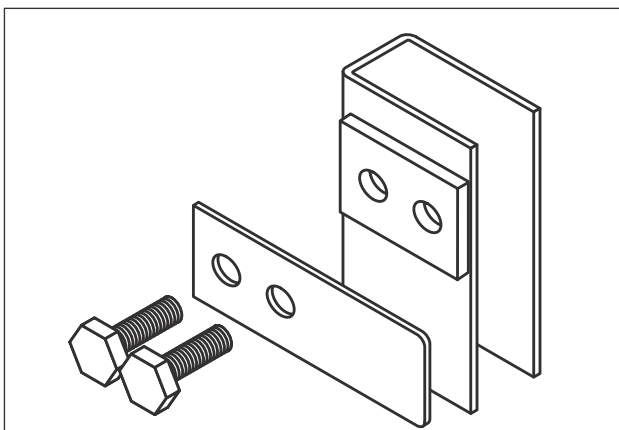

15 Attach the stops to the guide channels (as shown above) and if applicable attach handles to the bottom slat.

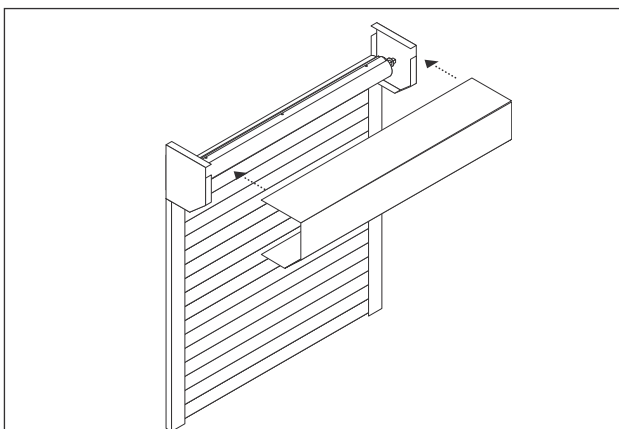

16 If required fit the hood / fascia. If the shutter is externally fitted the hood / fascia should be fastened using appropriately coloured 4mm rivets.

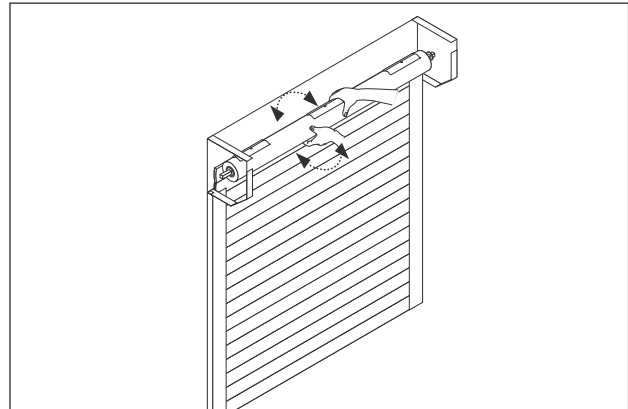

14 If required adjust the tension in the spring.
STOP RISK OF PERSONAL INJURY!
 For safety reasons it is advisable for the tension to be adjusted by two people.

Method 1:

Lift the curtain to the top so that it coils around the axle. Place cardboard between the lock and the curtain to prevent the lock from damaging the curtain. Now allow the bottom slat to come out of the top of the guides so that you can rotate the coil to add to or release the tension in the spring. To add tension to the spring turn the axle in the down direction.

To release tension from the spring turn the axle in the up direction.

Once adjusted feed the curtain back into the guide rails and test the operation. Repeat this process until the spring contains the correct amount of tension.

Method 2:

Lower the curtain to the floor. Turn the axle forward and insert the pin in the end of the spring to lock the axle (reverse of step 14). Detach the curtain from the axle. Carefully remove the pin then add or remove tension from the spring as appropriate.

To add tension to the spring turn the axle in the down direction. To release tension from the spring turn the axle in the up direction. Once adjusted replace the pin then continue as step 13.

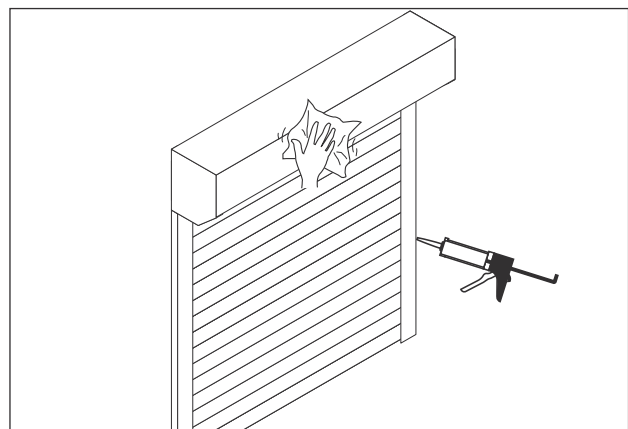

17 To complete the installation you should mastic around the edges of the shutter then give the shutter a final clean and tidy.

10.1 Spring Loaded Operation Installation Instructions (cont.)

Upon completion of the installation the owner of the shutter must be trained how to operate the product safely paying special attention to the following points:

- **The shutter should only be operated when in view**
- **The operator should ensure there are no objects or persons in the opening before and during operation.**
- **The end user must read and follow the advice given in the operating and maintenance instructions.**
- **In the event of a malfunction the end user should follow the advice given in the operating and maintenance instructions and if applicable contact the installer.**

10.2 Electric Operation Parts List

General Parts

- Assembled axle assembly (1 per shutter)
- Pair of flag assemblies (angle, guides, and endplates)
- Assembled curtain (depending on the shutter size may be supplied in sections)
- Steel hood
- Installation Instructions
- Operating and maintenance instructions

Operation specific parts

- Override handle (1 per shutter if manual override)
- Override handle clip (1 per shutter if manual override)

Electric control method (depends on method requested):

- Switch (with back box surface/flush)
- Key switch
- Remote control kit
- Group command
- Battery back up

Accessories are packed in a separate box.

If applicable angle & packer are usually packed with the guide rails.

Override handles



10.2 Electric Operation Installation Instructions

Before you begin installing the shutter please ensure you have read pages 4–9.

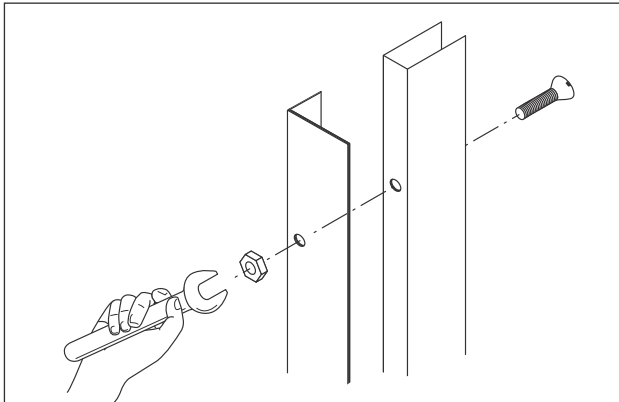

1 The channels are supplied with the angles attached these must be removed. If 30mm x 30mm packer box has also been attached this should also be removed. Please make a note of which sides the 30x30 box section was attached to as you will need to reattach it to the correct side in step 7.

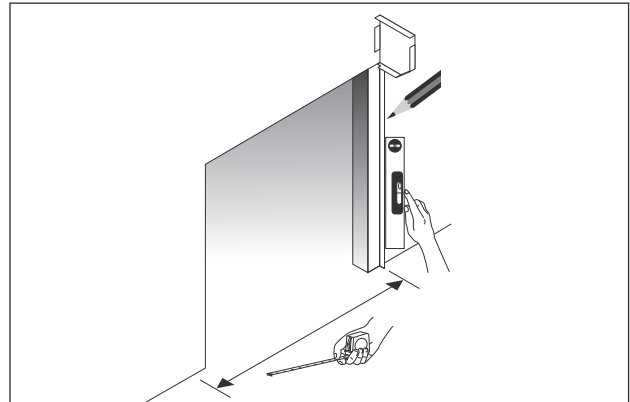

2 Measure the opening to determine the location of the first length of angle. If the floor is sloping you must fit the higher side first. Fix the angle to the wall.

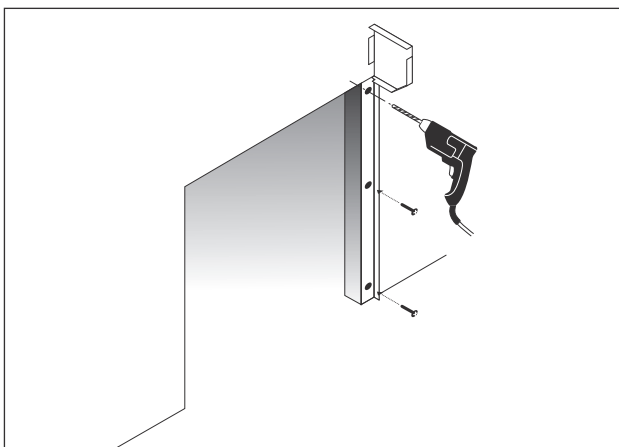

3 Offer angle up and fix to wall ensuring vertical (use all fixing holes provided)

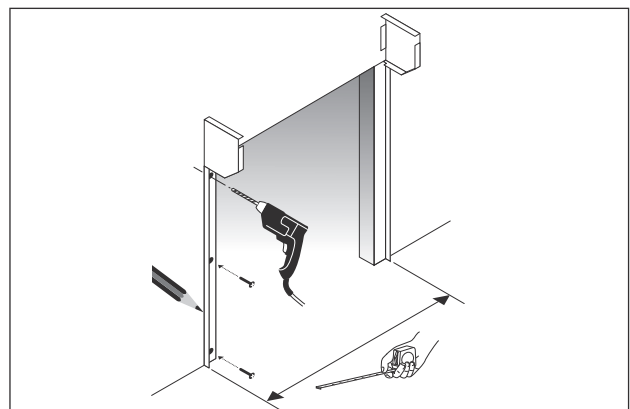

4 Measure from the first angle to determine the position of the second angle ensuring that the angles are vertical and also that the tops of the end plates are level. Fix the angle to the wall.

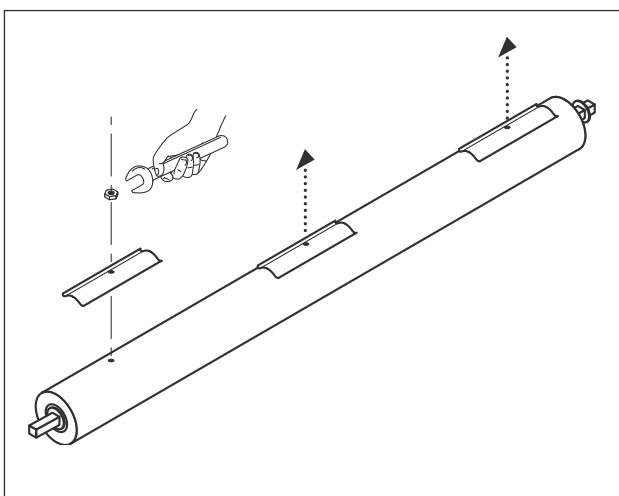

5 Remove the attachment strips from the axle.

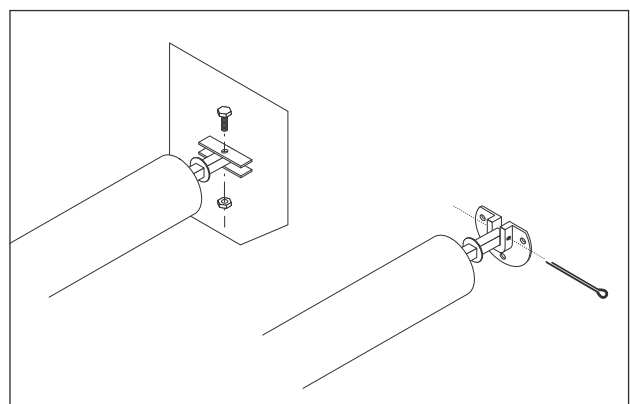

6 Attach the axle to the end plates using the fixings provided. You must ensure that the bolts located along the length of the axle for curtain attachment will be available for step 11.

10.2 Electric Operation Installation Instructions (cont.)

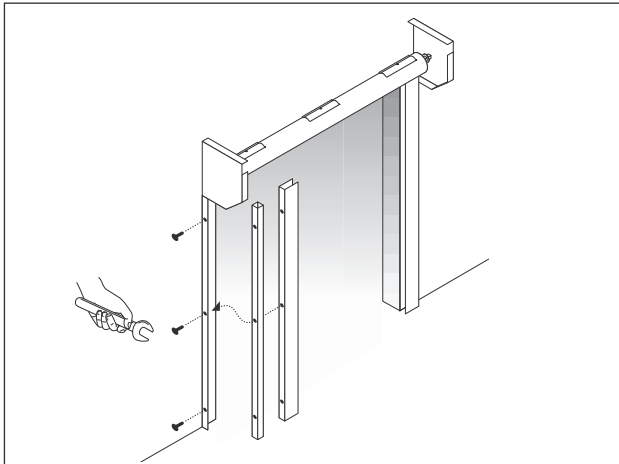

7 Attach the channels and the 30x30 box section to the angles if applicable.

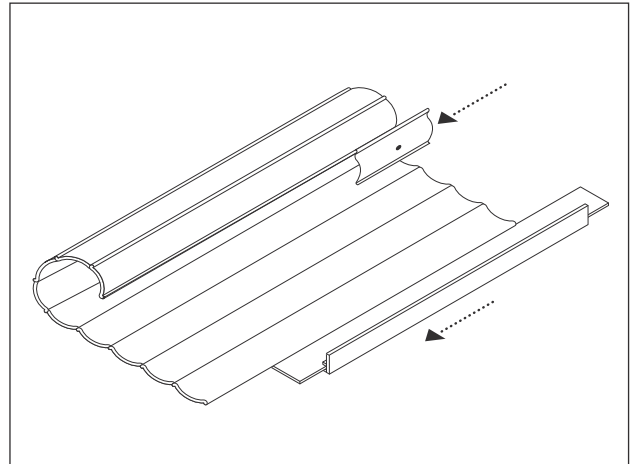

8 Slide the attachment strips on to the curtain.

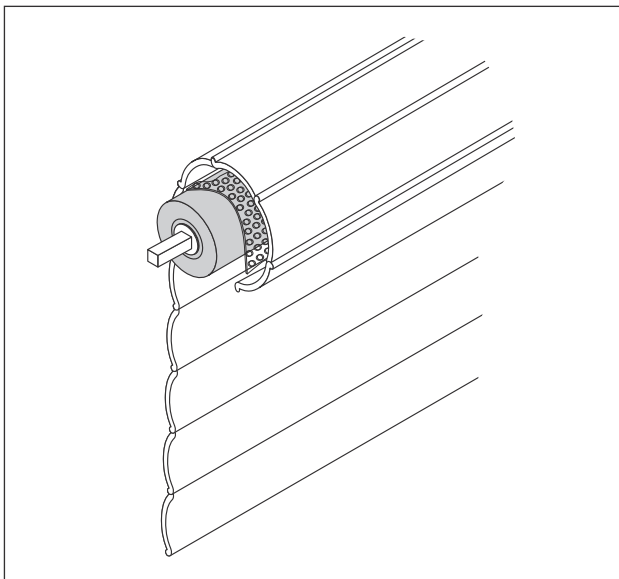

9 Large curtains will be supplied in two or more sections to enable them to be transported. There are two alternative methods for assembling the curtain:

Method 1

(If limited room, may require mechanical lifting assistance)

Slide the sections of curtain together before loading in the guide channels.

Method 2

Attach the top section of the curtain to the axle then rotate the axle in the up direction to roll the curtain around the axle. Then attach the next section of the curtain to the bottom of the first section. Repeat this process if applicable. Once all the curtain is coiled around the axle it can be lowered down into the guide channels.

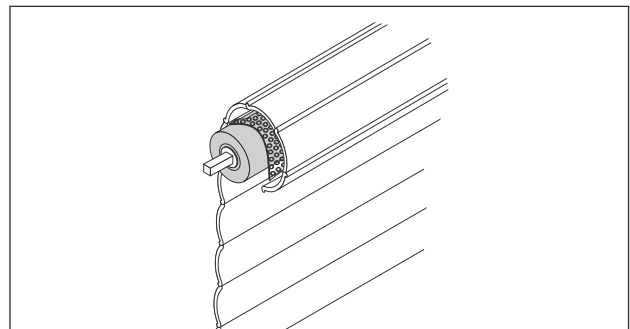

RISK OF MATERIAL DAMAGE!

10 Cover the axle with bubble wrap or a similar material to prevent the curtain from being damaged during the curtain loading process. Carefully load the curtain over the axle.



TIP – Place blocks on the floor under the bottom slat to raise the curtain off the ground. This will aid you to attach the curtain to the axle in the next step.

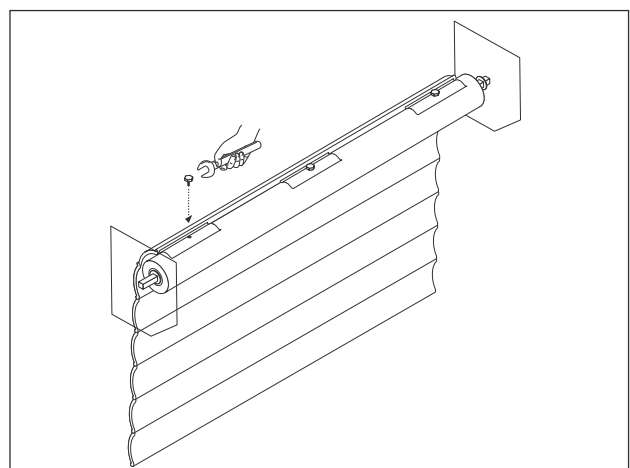

11 Attach the curtain to the axle using the attachment strips provided.

10.2 Electric Operation Installation Instructions (cont.)

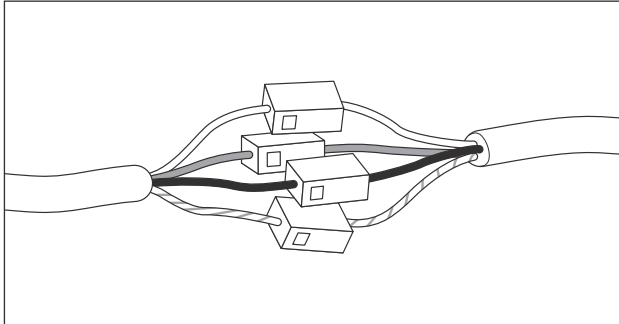

12 It is recommended that you use a test lead to set the motor limits or if a remote control is being supplied set the remote control into commissioning mode (see section 11.2). If a remote control is not being used or if you do not have a motor test lead the motor should now be wired to the switch supplied (see section 11).

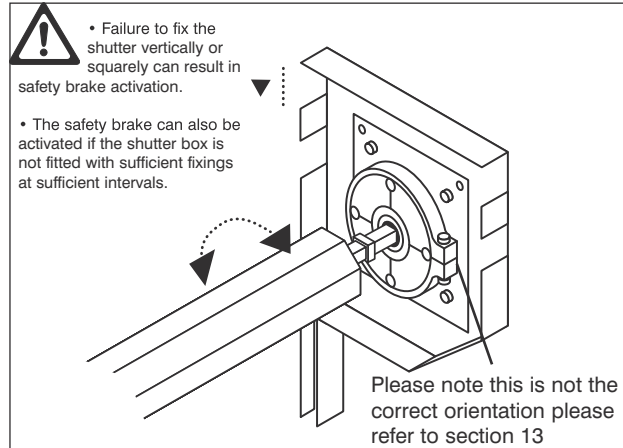

13 If applicable check anti-fall back device (see section 13.1)

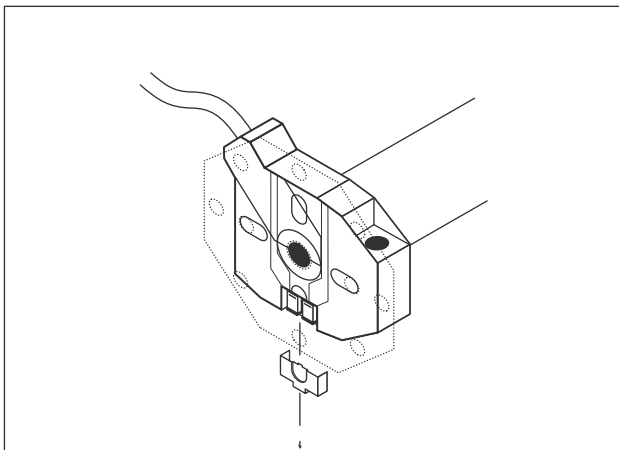

14 Set the motor limits (see section 12).

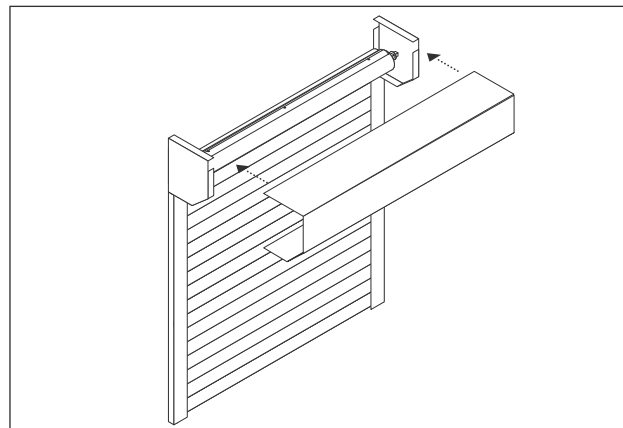

15 If required fit the hood / fascia. If the shutter is externally fitted the hood / fascia should be fastened using appropriately coloured 4mm rivets.

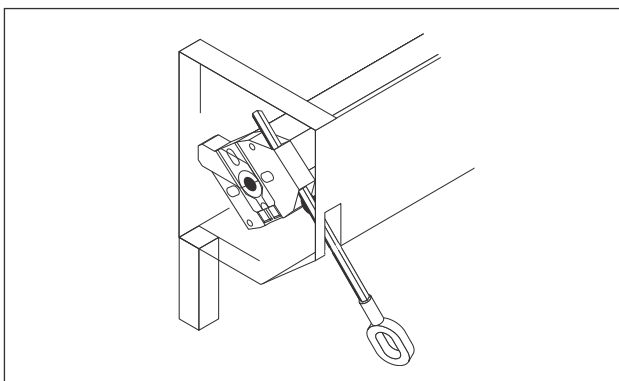

16 If applicable attach the override handle / rigid eye / drop eye to the shutter and test the manual override facility. Once you have identified which direction will open the shutter attach the label supplied to the override handle showing the end user which direction to wind the manual override to operate the shutter.

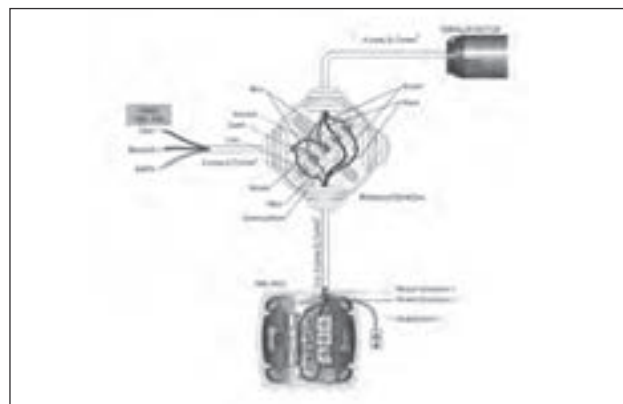

17 Wire the control method supplied to the shutter (see section 11 for further details). If an anti-drop brake has been supplied with a limit switch (wire attached to the anti-drop brake) this will also require wiring in at this stage (see section 13.1).

10.2 Electric Operation Installation Instructions (cont.)

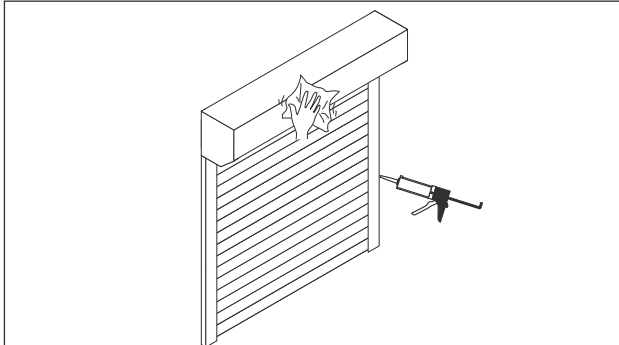

18 Test the operation of the shutter to ensure that the shutter moves freely up and down in the guide rails and that the shutter stops at its preset fully open and fully closed limits. If a remote control has been supplied with safety devices these should also be checked at this stage. To complete the installation you should mastic around the edges of the shutter then give the shutter a final clean and tidy.

Upon completion of the installation the owner of the shutter must be trained how to operate the product safely paying special attention to the following points:

- **The shutter should only be operated when in view**
- **The operator should ensure there are no objects or persons in the opening before and during operation.**
- **The end user must read and follow the advice given in the operating and maintenance instructions.**
- **In the event of a malfunction the end user should follow the advice given in the operating and maintenance instructions and if applicable contact the installer.**

If applicable complete CE documentation and label the product to comply with the Machinery Directive.

11 Electric Control Options

11.1 Connecting Hold To Run Switches

- 1 Mount switch box, in sight of the shutter
- 2 Connect to motor/mains
- 3 You must ensure you incorporate drip loops in your wiring before any control device and the motor to prevent water from running down the cables and into the control device or motor. Failure to do this will invalidate the products warranty.

For further details refer to separate wiring instructions.

N.B. If fitting two or more switches to the same door a Group Command control box will be required to prevent accidental damage to the motor. Only the keyswitch is suitable for external fitment.

Electrical Requirements

- All connections should be made in accordance with the 16th edition IEE Regulations.
- 5 Amp fuse recommended for fused mains supply for door
- Cable requirements
Mains supply cable; 3 core 1.5 sq mm
Motor cable; 4 core 1.5 sq mm
- There is a surge of current each time the door is operated, therefore, switches used in conjunction with any of the above motors should have contacts rated at a minimum of 16 amps to ensure trouble free operation.

Switching Requirements

- 1 Disconnect power to motor before undertaking any work.
- 2 Only one motor to be attached to a single pole switch.
- 3 A sequencing relay / group controller is required when operating one door by more than one switch.
- 4 Safety measures must be provided when doors are operated from out of sight of the main switch.
- 5 Group commands must be used where multiple motors are to be operated from one switch
- 6 Only approved momentary switches may be used on door installations. Otherwise all guarantees will be made null and void. Surface mounted switches are supplied as standard for all installations.
- 7 Warranty period on switches five year.

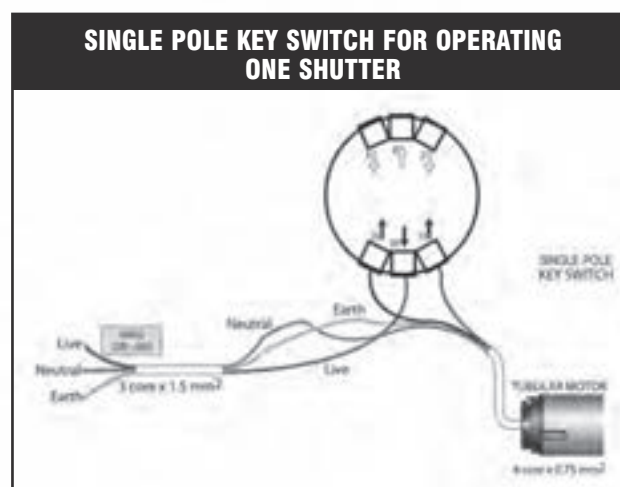

11.1 Connecting Hold To Run Switches (cont.)

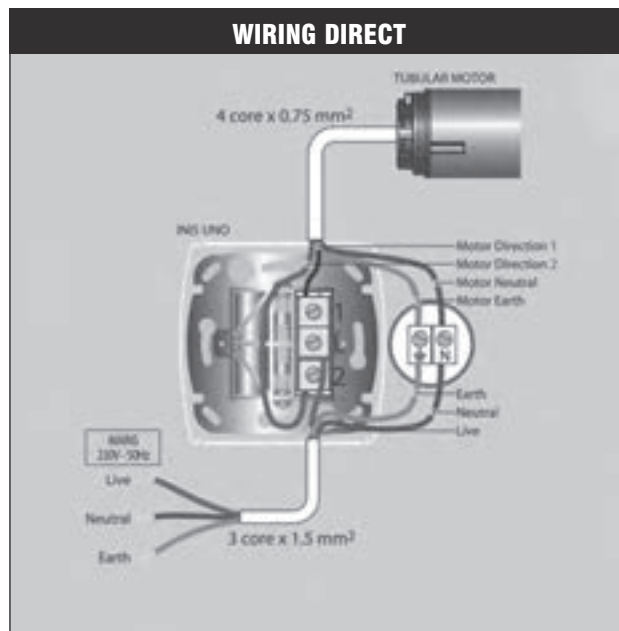
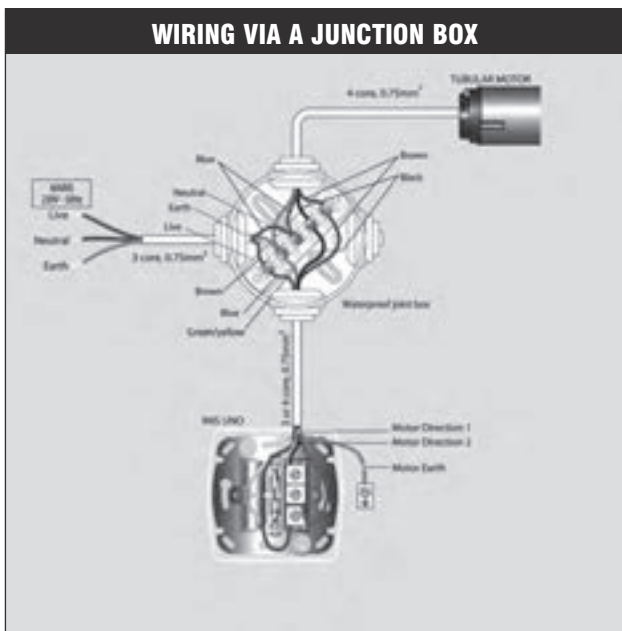

Either method of wiring is acceptable however the junction box method is recommended

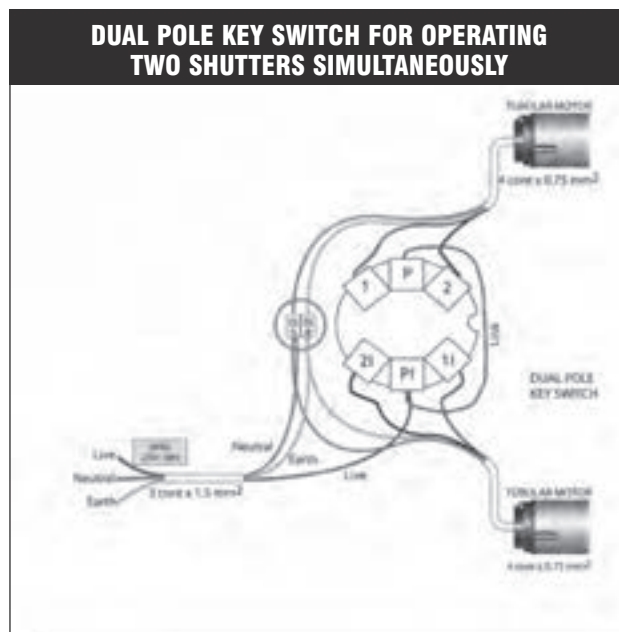
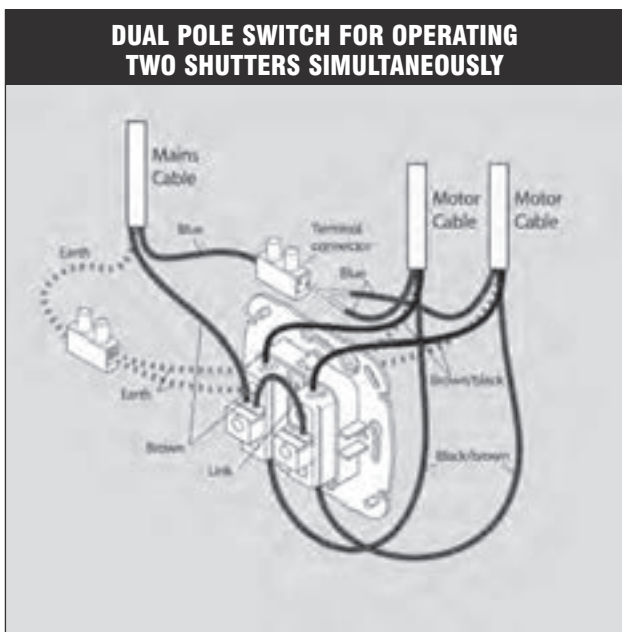

TROUBLESHOOTING		
FAULT	CAUSE	SOLUTION
The shutter/door fails to operate when the button is pressed/key is turned.	<ol style="list-style-type: none"> 1. There has been a power failure. 2. The wrong direction is been selected on the control equipment. 3. The thermal trip in the motor may have activated if the door has been operated several times recently. 	<ol style="list-style-type: none"> 1. Wait for power to come back on or operate the shutter/door with the manual override if installed. 2. Select the correct direction. 3. Allow the motor to cool for approximately 30minutes before attempting to operate the shutter/ door again.
The shutter/door stops before fully opening or closing, or fails to stop when reaching its final open or closed position.	The limits in the motor have failed to operate or may not have been set correctly.	Contact your installer.

11.2 Connecting the Remote Control

Power should be supplied via a 13 amp switched fused spur or a 13 amp switched plug socket. Plugs and spurs should be fitted with a 3 amp fuse. Ensure power is switched off before any electrical connections are attempted.

Remote Control

N.B. Do not fit the control / receiver unit externally (unless in a waterproof box), to structural steelwork, touching other power cables or fluorescent lights as the radio controls may not function correctly. Some components are pre-wired at the factory. If the door operates in the opposite direction to that expected reverse the black and brown motor wires. Ensure that any optional key switches etc. are set to the static position.



Please note the remote controls are available with either single channel or multi-channel hand transmitters. Multi-channel kits are supplied with additional set up instructions. Remote controls are also available in a hold to run form without safety devices. These units can be identified as the receiver has no bulkhead light and no integral controls on the receiver lid.

Reset button Sounder Dip switch block 2

Control unit LED terminal

Aerial terminal

S E C button

Dip switch block 1

Switches - up, stop, down

Front cover buttons terminal

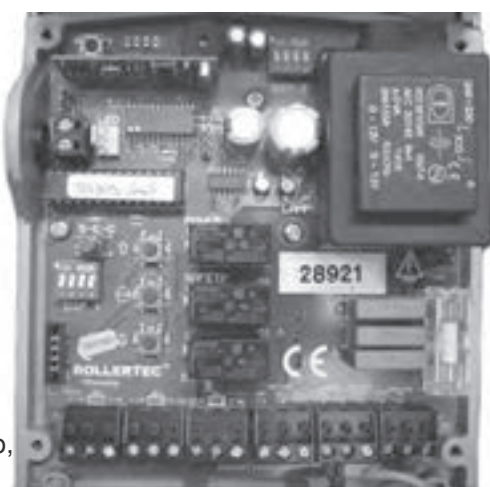

Fuse

Removable terminals

REMOVABLE TERMINALS	TERMINALS	DESCRIPTION
T1	○	Mains live (brown/red)
T2	○	Mains neutral (blue/black)
T3	○	Mains earth (yellow & green)
T4	○	Motor earth (yellow & green)
T5	○	Lamp live
T6	○	Lamp neutral
T7	○	Motor neutral (blue)
T8	○	Motor down close (black r/h motor or brown l/h motor)
T9	○	Motor up open (brown r/h motor or black l/h motor)
T10	○	Photo electric cell + 12V (brown)
T11	○	Photo electric cell OV (blue)
T12	○	Link always required
T13	○	Push button
T14	○	Push button
T15	○	Push button
T16	○	Photo electric cell auto test (black)
T17	○	Link removed only if photo electric cell is installed
T18	○	Photo electric cell safety input (white)

Please note the photo electric cell is optional

Installation of control / receiver unit

- 1 Mount control box with light on top on a flat surface so as to prevent twisting and damage to PCB. (Mark fixing holes and move unit out of way to prevent debris fouling PCB when drilling holes).
- 2 Fit both aerials and set parallel to wall. The aerials must not touch.
- 3 Wire motor to control unit making sure a 'drip loop' is incorporated into any cables coming into the unit from above.
- 4 Connect to the mains supply.

Additional Wiring Information

Please note the middle button on the standard momentary Somfy Inis Uno switch does not function as the open and close buttons are normally hold to run. When connected to the SeceuroSmart (RT) these buttons will adopt impulse functionality.

To stop the door when it is closing press the open button once.

To stop the door when it is opening press the close button once.

If for any reason the door is stopped when it is partially open the switch will adopt hold the hold to run function in the close direction. To reset the safety device the door needs to be fully opened.

Wiring a momentary switch into a remote control.

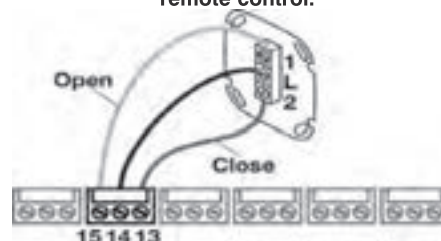

11.2 Connecting the Remote Control (cont.)

Maintenance & Setting Of Motor Limits

[Dip switch block 1] Dip switches 1, 2 ,3 ON and 4 OFF



This mode is used when tensioning an anti-fall back spring in the axle, maintenance and setting the motor and limit switch positions.

All safety inputs and transmitters are ignored, only the switches mounted on the circuit board, control box lid or any external switches wired into it remain active. They operate on a 'dead man' / hold to run basis. This allows motor limits to be set, without the need for a dedicated test lead. Turn to section 12 for instructions on setting the motor limits. Once the motor limits have been set you can continue with setting up the remote control.

The lid mounted signal LED on the front of the control unit will indicate the current position of the door as detailed below:

GREEN with off flicker; door open/open limit activated	Flashing GREEN; door opening
RED with off flicker; door closed/close limit activated	Flashing RED; door closing
YELLOW with off flicker; door stationary between limits	

Maintenance

Selecting the commissioning mode during maintenance isolates any key fobs loaded on to the system. This enables the service engineer to carry out maintenance without having to spend time recalling key fobs from members of staff, it also covers both the service engineer and the servicing company from prosecutions should an accident occur from a rogue fob operating the door which was not handed in prior to the maintenance commencing.

If you remove the cover from the remote control receiver during maintenance you must disconnect the ribbon from the printed circuit board. The ribbon cable can be damaged if the receiver lid hangs by the ribbon cable. Before fastening the lid back on the receiver you must reconnect the ribbon cable to the printed circuit board.

Wireless Safety Edge

The Safety Edge is fitted to the bottom of the door and is activated when the door starts to close. If it comes into contact with an object while the door is closing, it transmits a signal to the wall mounted control unit, the door will then stop and reopen a short distance.

The safety edge also works as a weather seal, designed to be pressed against the ground, to prevent false sensing and re-opening it is disabled within the last 50mm of door travel.

Attaching The Bottom Slat Transmitter



Feed the wire through the bottom slat transmitter rubber seal then attach to the connector.



10mm max. gap

Attach the bottom slat transmitter to the bottom slat using the screws provided. Do not use a power operated screwdriver as it could distort and damage the printed circuit board.

11.2 Connecting the Remote Control (cont.)

Fitting The Magnet Housings - Internally Fitted Doors

1. Prepare the surface of the guide rail before attaching the magnet holder by cleaning the relevant area with the wipe provided and then allow to dry (if required remove the magnet from the housing).

When two doors are being installed side by side, next to each other you must avoid positioning the top magnets parallel to each other. One of the top magnets must be located 20mm below the other top magnet, this will prevent the neighbouring magnet from interfering with the system.

If templates (orange card) have been supplied with the remote control we recommend that they are used to ensure that the magnets are positioned correctly.

2. When the curtain is fully raised (on the top limit) attach the top magnet (50mm below the bottom slat transmitter), with the flat edge facing the curtain and in line with the inner edge of the guide (as shown on diagram).
3. Attach the bottom magnet 200mm from the floor again ensuring the flat face is in line with the guide and facing the curtain.
4. Push the magnets on firmly, using the attached double sided tape. The magnet holders must be fastened in place using the screws provided in the outer fixing holes once the safety edge has been successfully commissioned.

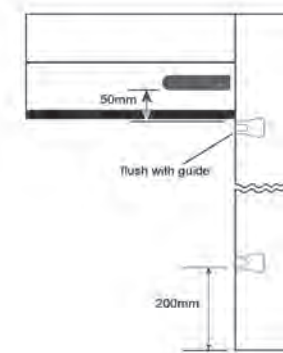

Fix

Fitting The Magnet Housings - Externally Fitted Doors

The bottom slat transmitter must always be fitted on the internal face of the bottom slat. To enable the bottom slat transmitter to detect the magnets whilst it travels up and down the magnets must be mounted on the internal face of the guide rails.

If the guide rails are face fixed they must be mounted at the edge of the openings to enable the transmitter to pass close enough to the magnets. The magnets must be sandwiched between the guide rails and the surface they are being fitted to.

The magnets can be removed from the magnet housings to reduce the size of recess hole required.

1. When the curtain is fully raised (on the top limit) position the top magnet (50mm below the bottom slat transmitter), with the flat edge facing the curtain and in line with the inner edge of the guide (as shown on diagram).
2. Position the bottom magnet 200mm from the floor again ensuring the flat face is in line with the guide and facing the curtain.
3. We recommend that you secure the magnets into the holes using a silicone sealant.

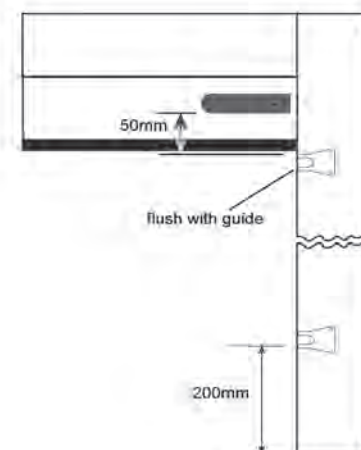
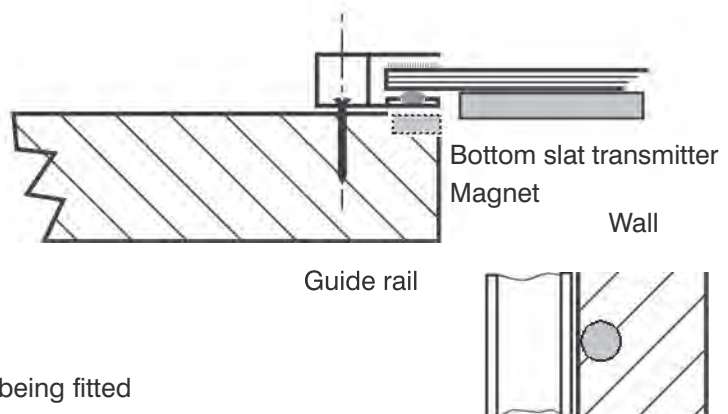

11.2 Connecting the Remote Control (cont.)

Safety Edge Commissioning

- 1 Open the door fully
- 2 Place a screwdriver shaft (between 10 and 30mm diameter) on the floor so that the door can close on to it during the commissioning process. If the floor is uneven place the screwdriver at the highest point on the floor.
- 3 Press and hold the S-E-C button (Safety Edge Commission) until the unit gives an audible beep (approx. 5 seconds).

The door will now automatically cycle through the six stage commissioning sequence shown below.

STAGE	OPERATION	CONFIRMATION SIGNAL
1	The door will travel DOWN past the top magnet and stop	single BEEP and the courtesy light will FLASH ONCE
2	The door will travel UP to the fully open position and stop	single BEEP and the courtesy light will FLASH ONCE
3	The door will travel DOWN to the floor and detect the screwdriver shaft	single BEEP and the courtesy light will FLASH ONCE
4	The door will travel UP until it passes the bottom magnet and will then stop	single BEEP and the courtesy light will FLASH ONCE
5	The door will travel DOWN to the floor and detect the screwdriver shaft for a second time.	three BEEPS
6	The door will travel UP to the fully open position and stop.	

- 4 Remove the screwdriver. Now operate the door and test the safety edge to ensure that it works correctly.

If the commissioning sequence fails at any stage the door will **stop** and the sounder will emit a **five second beep**. If this occurs check the following:

- Aerials fitted and not touching
- Magnets in correct positions
- Bottom slat transmitter passes within 10mm of magnets
- No interfering signals being emitted by local devices (PIR detectors, weather stations, TV signal boosters)
- Suitably sized screwdriver placed on the floor for stages 3 and 5 (see above)

Adding The Safety Edge Transmitter

The safety edge transmitter attached to the bottom slat is automatically added to the receiver unit during a successful safety edge commissioning process.

11.2 Connecting the Remote Control (cont.)

Deleting The Safety Edge Transmitter

To delete a safety edge transmitter you will need to remove it from the bottom slat and remove the weather seal to access the button inside.



Button

1. Press the button once and the light on the front of the transmitter will light dimly.
2. Press the button four times and on the fourth time the light will do a long bright flash and the receiver unit will beep.

ADDING TRANSMITTERS

Transmitters can either be added using the onboard Dipswitches or with a transmitter that is already loaded onto the control unit.

METHOD 1 – Using dipswitches

- 1 Turn Dipswitch 4 ON, then wait 2 seconds.
The lid mounted signal LED will give a slow YELLOW flash.
- 2 Press the open button on the board.
The flashing LED will change from flashing YELLOW to flashing GREEN.
- 3 Now press the top green button on the new transmitter once and release.
The flashing LED will change to continuous for 1 second each time it accepts a new transmitter.
- 4 Repeat step 3 for all other transmitters to be added on to the system.

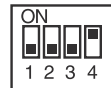

Note the manufactures code for the transmitter must match the manufacturers' code for the receiver, if they do not match, you cannot add that particular transmitter on to the system, the LED will flash RED, GREEN then YELLOW once quickly, if they are not compatible.

If you do not select Add mode the unit will time out and flash the signal LED, RED / GREEN. To return to flashing YELLOW press the stop button on the board.

To exit programming mode set dipswitch 4 to OFF

METHOD 2 – Existing transmitter method

- 1 Press and hold down the Grey button on a transmitter that is already loaded onto the control unit.
The lid mounted signal LED will flash YELLOW slowly, keep the button held down until it flashes YELLOW quickly.
- 2 Release the Grey Button.
The lid mounted signal LED will continue to flash YELLOW quickly.
- 3 Press the top green button on the same transmitter once.
The flashing LED will change from flashing YELLOW to flashing GREEN.
- 4 Now press the top green button on the new transmitter once and release.
The flashing LED will change to continuous for 1 second each time it accepts a new transmitter.
- 5 Repeat step 4 for other transmitters to be added on to the system.

11.2 Connecting the Remote Control (cont.)

- Thirty seconds after loading the last transmitter the LED changes to flashing yellow for ten seconds and then returns to normal running mode. Alternatively you can press the top green button of a transmitter that has just been loaded, this will take it straight back to normal running mode.

Note the manufactures code for the transmitter must match the manufacturers code for the receiver, if they do not match, you cannot add that particular transmitter on to the system, the LED will flash RED, GREEN then YELLOW once quickly, if they are not compatible. Please contact PDT for further details.

Deleting Transmitters

Transmitters can either be deleted using the onboard Dipswitches or with a transmitter that is already loaded onto the control unit.

METHOD 1 – Using DIP switches

Warning: This will remove all the existing transmitters from the system.



- Turn DIP switch 4 ON, then wait 2 seconds.
The lid mounted signal LED will give a slow YELLOW flash.
- Press and hold down the stop button on the board until the following sequence has been carried out
The flashing LED will change from flashing YELLOW to a fast flashing RED. After 10 seconds it will turn solid RED, after a further 5 seconds it will turn solid YELLOW and then after a further 2 seconds solid GREEN. You must release the stop button when the LED is GREEN.

All transmitters have now been deleted from the system. The lid mounted signal LED will flash RED/YELLOW/GREEN repeatedly until Dipswitch 4 is turned OFF.

If you do not select Delete mode the unit will time out and flash the LED, RED / GREEN. To return to flashing YELLOW press the stop button on the board. To exit programming mode set dipswitch 4 to OFF

METHOD 2 – Existing transmitter

Warning: This will remove all the existing transmitters from the system except for the one it is carried out with.

- Press and hold down the Grey button on the existing transmitter.
The lid mounted signal LED will flash YELLOW slowly, keep the button held down until it flashes YELLOW quickly.
- Release the Grey Button.
The lid mounted signal LED will continue to flash YELLOW quickly.
- Press the stop button on the same transmitter until the following sequence has been carried out.
The flashing LED will change from flashing YELLOW to a fast flashing RED. After 10 seconds it will turn solid RED, after a further 5 seconds it will turn solid YELLOW and then after a further 2 seconds solid GREEN for 2 seconds.
You must release the stop button when the LED is GREEN.

All transmitters except the one used to carry out the delete command have now been deleted from the system and it will automatically return to normal running mode.

11.2 Connecting the Remote Control (cont.)

Optional Photo cell

Mounting & Adjusting Photo-electric Cell

- 1 bolt photocell and reflector to plastic brackets and fix photocell internally at car bumper height (500-700mm above floor)
- 2 switch on the power (green LED will illuminate)
- 3 ensure visible red beam is centred on reflector (yellow LED will illuminate) and move reflector left and right, up and down, marking point LED goes out to locate centre
- 4 Fix reflector kit using the bolts and screws provided. Using other fixings will damage the internal parts of the photocell unit.

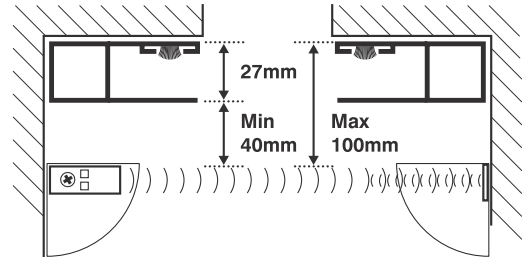

When a photo cell is fitted the DIP switches should be set to 1 ON and 2, 3 and 4 OFF. This activates the Photo Electric Cell self check test which will monitor the safety device. If there is a fault with the safety device or the wiring the door will automatically stop and go into hold to run mode and the LED signal light will indicate the fault.

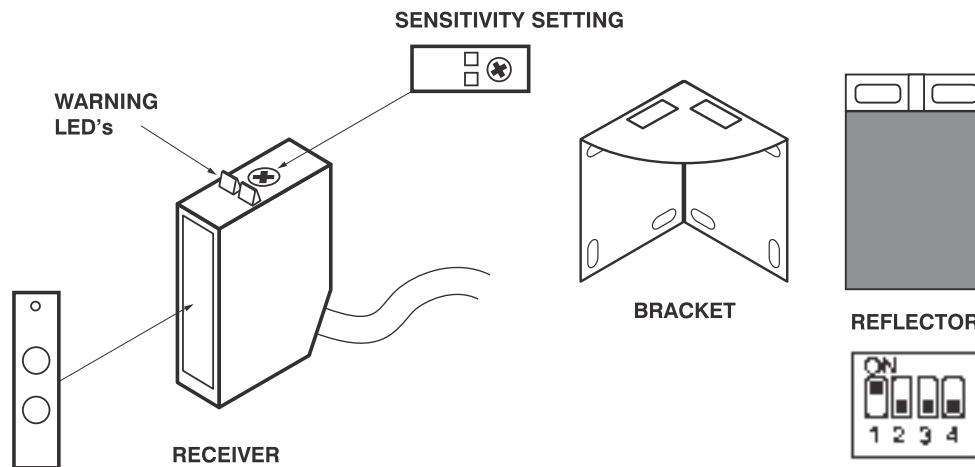

Additional Features of the Seceurosmart

Pin Lock & Stall Detection

When an open command is given from the **fully closed, close limit position** and pin/ground locks are left in place, SeceuroS-mart detects the motor starting to stall when tension is applied to the curtain; SeceuroSmart automatically stops the door and then reverses direction sending the shutter back to the fully closed position.

If the motor starts to stall **part way through an open movement (this could occur if a person/object is drawn in to the coil or a person/object is lifted by the shutter)**, SeceuroSmart automatically stops the door and then reverses direction for approximately 2 seconds, releasing or lowering anything that was lifted or trapped by the shutter.

Every time a pin/ground lock or stall detect occurs a ten second time out disables the open command, preventing the operator from repeatedly trying to open the door with the pin/ground locks engaged.

A visual indication is given on the signal LED as detailed in the *System Status* Indication section.

Please note that during a power failure if the unit is fed from a PDT battery backup, the controls revert to 'Dead Man' operation and pin/ground lock or stall detect is disabled.

Thermal Trip Monitoring

SeceuroSmart constantly monitors the thermal trip embedded inside the motor. If the motor is operated

11.2 Connecting the Remote Control (cont.)

frequently it will over-heat and activate the thermal trip. Displaying the thermal trip activation prevents the user from calling out an engineer, only to find the shutter started working again, as the thermal trip automatically reset as the motor cooled down.

A visual indication is given on the signal LED as detailed in the *System Status* Indication section.

Relay Weld Monitoring

SeceuroSmart monitors the power relays that switch electricity to the motor. The use of redundancy technology (**a legal requirement**) ensures that the shutter can always be brought to the stop position irrespective of mechanical or electrical failure of the motor power relays.

A visual indication is given on the signal LED as detailed in the System Status Indication section.

Service Counter

SeceuroSmart Counts the number of times the door is opened, this information can then be used to help provide the correct level of service required to maintain the door in optimum condition. The current count can be displayed on the signal LED by pressing and holding the stop button on 'power up' or 'reset'.

The count is then shown in the following format

Quick **RED** flash (1/4 sec on 1/4 sec off) indicates thousands (one flash per thousand operations)

Quick **YELLOW** flash indicates hundreds (one flash per hundred operations)

Quick **GREEN** flash indicates tens (one flash per ten operations)

Quick **RED** flash indicates units (one flash for each operation)

A long flash (One second) of any of the above colours indicates a zero for that count.

Dip Switch Summary

DIP SWITCH (up)	BLOCK 1	BLOCK 2*
1	PEC self check	Stall detect off
2	Hold to run operation when opening	Generator supply
3	Hold to run operation when closing	Any motor (Hercules 5 wire without safety edge)
4	Adding hand transmitters	Stop and then longer pause before return

*The dip switches on block 2 are only read on power-up so if you change the dip switch positions on this block you will have to press the reset button or turn the power off then on again for the change to take effect.

Remote Control Trouble Shooting Guide

N.B. Always isolate the power before attempting to make any adjustments or repairs. Untrained operators are advised to contact an approved installer.

System Status Indication

The status of the control unit and/or door is indicated by the lid mounted signal LED. This is a three-colour "RED, YELLOW & GREEN" lamp (LED) mounted on the front of the control unit, as detailed below:

DOOR POSITIONS	
LED SIGNAL	STATUS
GREEN solid	open limit activated
GREEN flashing	door opening
RED solid	close limit activated
RED flashing	door closing
YELLOW solid	door stationary between the open and close limits

11.2 Connecting the Remote Control (cont.)

Remote Control Trouble Shooting Guide (cont.)

System Status Indication (cont.)

SYSTEM STATUS		
LED SIGNAL/FAULT	CAUSE	SOLUTION
RED rapid flashing	Photo Electric Cell (PEC) beam broken. No PEC connected to the receiver. Link missing between terminals 17 and 18.	<ol style="list-style-type: none"> 1 Remove any obstacles which may be in the doorway (once you have removed the obstacle the signal light will change to solid yellow). 2 Ensure the photocell and reflector are clean. 3 Re-align the photo cell and reflector. 4 Turn dip switch 1 off. 5 Replace the link between terminals 17 and 18.
RED flash then two YELLOW flashes	A motor stall has been detected	<ol style="list-style-type: none"> 1 Disengage manual locking device 2 Remove any objects which may have jammed in the guide rails, curtain or roll. 3 Ensure nobody is attempting to ride up on the curtain. 4 Ensure a non-approved item has not been attached to the curtain. 5 In extreme conditions the door may have frozen to the guide rails or floor. Try to operate the door again or defrost the frozen section.
RED flash then three YELLOW flashes	The thermal trip has activated on the motor or the motor is not connected.	<ol style="list-style-type: none"> 1 Allow the motor to cool for approximately 30minutes before attempting to operate the door again. 2 The motor may not be connected to the remote control unit.
RED flash then four YELLOW flashes	Door overrun time out; the door has been opening or closing for over 60 seconds without detecting a final end limit position.	<ol style="list-style-type: none"> 1 Re-set the motor limits 2 If the motor limits can not be set the motor may be faulty.
A rapid RED, GREEN then YELLOW single flash	Indicates that a signal has been received from either a transmitter that has not been loaded on to the system or the transmitters' manufacturers code does not match with the SeceuroSmart control unit.	<ol style="list-style-type: none"> 1 Load the transmitter on to the system as per the "Adding transmitters" section.
Long YELLOW then two shorter RED flashes	PEC has failed Self Check test.	<ol style="list-style-type: none"> 1 Check the PEC wiring. 2 Replace faulty PEC
Reduced operating range	Batteries in transmitter are flat or aerials may not be fitted to remote control unit or they may be touching.	<ol style="list-style-type: none"> 1 Transmitter LED does not illuminate when flat and if batteries low it flashes when button pressed. Replace batteries. 2 Ensure aerials are not touching, replace aerials if they are missing. 3 The door can be closed by pressing and holding a close button. Release the button once the door is fully down and locked.
The door stops automatically after the bottom edge of the door has passed the top magnet when the door is closing (this only applies when bottom slat safety edge is installed).	<p>Signal interference.</p> <p>Aerials are touching or have been removed.</p> <p>The top magnet is missing or in wrong location.</p> <p>Fault detected in safety edge circuit</p>	<p>A local device (such as a PIR detector, a weather station or a TV signal booster) is transmitting a signal on the same frequency. The receiver will wait for the signal to stop before operating the door again.</p> <p>Ensure aerials are present and are not touching.</p> <p>If the magnet is on the guide rail ensure that it is located at least 50mm below the bottom slat transmitter when the door is fully open.</p> <p>If the bottom slat transmitter is flashing 6 or 8 times contact your supplier.</p>

PROGRAMMING MODE (Using a transmitter)

LED SIGNAL	STATUS
Slow flashing YELLOW then quick flashing YELLOW	control unit in programming mode

PROGRAMMING MODE (Using the buttons)

LED SIGNAL	STATUS
RED and GREEN flashing alternatively	Timed out during programming you will need to press the reset button
YELLOW slow flashing	Receiver unit in programming mode

11.3 Alternative Control Methods



For information on the following electric control options please refer to the individual instructions supplied with the accessory:

- **Group Command**
- **Battery backup**
- **Digital key pad**
- **KS02 - Anti-tamper key switch**

12 Setting Motor Limits

In some instances, due to the handing of the motor and the override position required, it may be necessary to supply the motor with limit setting tools fitted. If they are fitted as shown in the diagram below then the limit setting tools will need to be pulled rather than pushed when following the instructions below.



1. Ensure the control switch is in the OFF position.



2. Remove the protective cap from the head of the motor.



3. Fully depress both limit switch push buttons. They will automatically lock in the down position. Operate the control switch and check the direction of rotation. If it is incorrect, turn the switch OFF, reverse the black and brown motor direction wires and try again.



4. Identify the UP limit switch push button. Press the control switch to the UP direction until the required position is reached then turn the switch OFF.

Unlock the UP limit switch push button by depressing and releasing it to set the limit.



5. Repeat the above operation to set the lower limit.

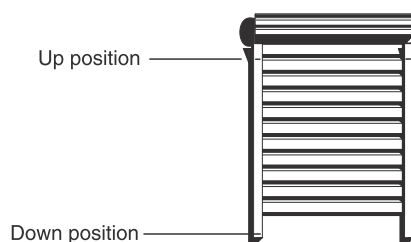

*Two positions have to be set :
the UP and DOWN positions, this is where the motor will stop automatically.*

6. Check with the control switch that the motor stops at the UP and DOWN positions just set.



7. Refit the protective cap (take care not to depress the push buttons).

When checking the operation of manual override turn off the power prior to operating crank handle.

13 Anti-fall Back Devices

Introduction

If required the shutter you have received will have been supplied with an anti-fall back device. This anti-fall back device could either be an anti-fall back spring or an anti-drop brake depending on the type of shutter and the method of operation. If a safety device has been supplied there will be labels located inside the shutter box indicating which safety device has been installed.

Please find following information on the anti-drop brake and anti-fall back springs to assist you with the installation of the shutter.

13.1 Anti-drop Brakes Electric Operation

General information

The anti-drop brake supplied is essentially a bearing which allows the axle to rotate freely until the axle reaches a speed of approximately 22 revolutions per minute. When the axle speed reaches 22RPM the anti-drop brake will lock preventing the axle from rotating. If the brake is also fitted with a micro switch this will cut the power to the motor at the same time as the brake locks.

Please note this device will only function correctly when the shutter box is in the standard upright position.

Installation

If an anti-drop brake is required it will be supplied attached to the end plate inside the pre-assembled shutter box.

The anti-drop brake may have a micro switch fitted. If this is the case it will need wiring as per the wiring diagram.

If there is no micro switch fitted there is no requirement for any further set up and the shutter can be installed as normal.

Resetting after activation

In the event of an anti-drop brake activation you must follow the procedure below to reset the brake:

For safety reasons please ensure there are no people or objects in the shutter opening before and during the process of resetting the anti-drop brake.

Check the fixings which hold the shutter box in place to ensure the activation process has not weakened any of the fixings.

Make sure there are no objects trapped in the shutter guide rails or shutter box which could be preventing the shutter from moving.

If the anti-drop brake has a micro switch fitted you will need to isolate the mains power supply to the shutter. Unwire the anti-drop brake from the wiring circuit and link the neutral from the motor to the neutral from the power supply.

Once this is complete, or if the anti-drop brake does not have a micro switch fitted, you can attempt to operate the shutter in the up direction.

When you attempt to operate the shutter in the up direction there are three possible outcomes:

Wiring a safety brake into a circuit with a motor and a standard switch

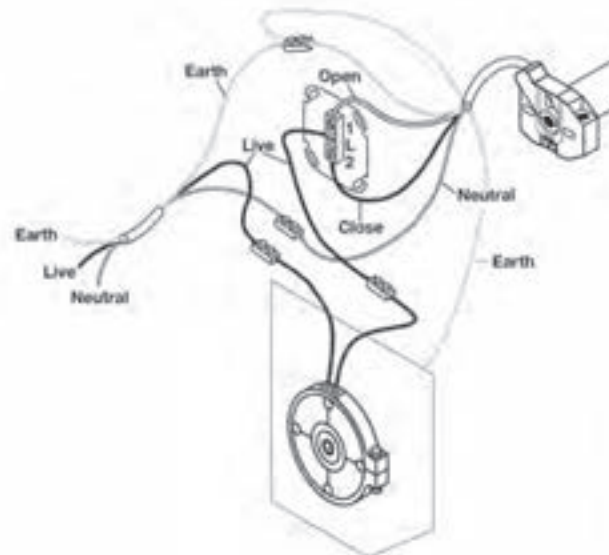

13 Anti-fall Back Devices (cont.)

CURTAIN ACTION	CAUSE	SOLUTION
Curtain goes up and stays up	The shutter is OK.	Lower the curtain to its fully closed position then reset the anti-drop brake as described below.
The curtain will not go up	1) The wiring has been damaged or a wire has been disconnected. 2) If you can hear the motor turning but the axle is not rotating the motor gear box may have failed or the drive wheel has detached from the axle	1 Check the wiring to ensure there are no damaged cables and every wire is connected correctly. 2 Carefully release the collar on the anti-drop brake using a 6mm allen key. As you release the collar the curtain will begin to lower to the ground. Once the curtain has reached the ground you will be able to remove the axle assembly, repair / replace the faulty item then reset the anti-fall back device.
The curtain goes up but when you stop the shutter it begins to fall again	The brakes in the motor may have failed	Press the up button to raise the curtain then quickly press the down button to lower the curtain to the ground in a controlled manner. Once the curtain has reached the ground you will be able to remove the axle assembly, repair / replace the faulty item then reset the anti-fall back device.

To reset the anti-drop brake you must rotate the inner section of the brake until the black lines on the inner and outer sections of the anti-drop brake are in line with each other. If you are unable to rotate the inner section release the collar using a 6mm Allen key. Once realigned the collar should be tightened using the appropriate amount of torque as stated right. If the collar is not tightened to the correct amount it will prevent the safety device from working correctly.

	TORQUE
RD80 Anti-drop brake without micro switch	15 Nm
RD150 Anti-drop brake with micro switch	8 Nm
1/2 Anti-drop brake with micro switch	20 Nm

Correct Alignment Of Safety Brakes

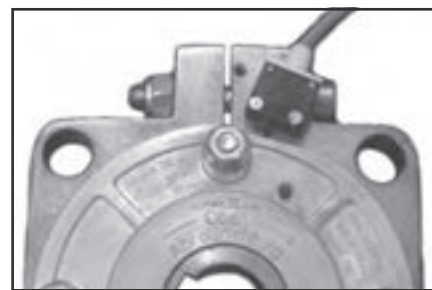

If after activation you are unable to reset the brake as shown above you will need to reorder a replacement brake, which will be chargeable. Once you have swapped the brakes over the activated brake should be returned to your supplier for inspection. As long as the safety brake has not been damaged the brake will be reset and returned to you for use as a spare.

13 Anti-fall Back Devices (cont.)

13.2 Anti-Fall Back Springs Electric Operation

General information

The anti-fall back spring is supplied in addition to the standard motor and will be supplied fitted in the opposite end of the axle to the motor. The spring supplied will prevent the curtain from falling in the event of a motor failure.

Installation

If an anti-fall back spring is required it will be supplied inside the pre-assembled shutter box.

If an anti-fall back spring has been supplied fitted in the axle you must tension the spring as follows before you can attach the curtain to the axle:

- 1 Connect the motor to either a test lead or the remote control. The remote control must be in commissioning mode see separate instructions.
- 2 Remove and retain the limit cover cap from the motor. Fully press in the limit switches on the motor. Using either the test lead or remote control rotate the axle in the close direction (see drawing A and label on axle).
- 3 The number of turns required will be clearly stated on a label.
- 4 When complete the axle will be fully tensioned and will be ready for installation and attachment of the curtain in the fully closed position.

Replacing the motor or anti-fall back spring

- 1 Lower the curtain to the fully closed position.
- 2 Disconnect the curtain from the axle.
- 3 As the axle contains an anti-fall back spring the tension must be removed from the spring before attempting to remove the axle. To remove the tension you must rotate the axle in the direction which would open the door the number of turns stated on the label provided.
- 4 Isolate the mains power then disconnect the motor leads from the control unit.
- 5 Remove screws securing motor octagonal fixing plate and lever out retaining tabs with a screwdriver
- 6 Remove split pin from the spring shaft and slide shaft free of fixing plate.
- 7 Lift axle out
- 8 If you need to replace or remove the motor, unbolt the octagonal fixing plate and drill out rivets in the axle securing the motor, make sure that any loose drilled out rivet 'slugs' are removed from inside the axle to prevent them making an unnecessary rattling noise.
- 9 The anti-fall back spring are also held in place by rivets and should be removed in a similar manner.
- 10 Replace the motor / anti-fall back spring, re-rivet and refit the octagonal fixing plate to the motor end.
- 11 Install the axle assembly remembering to tension the anti-fall back spring as per the instructions above.
- 12 Re-connect motor lead to the control unit.
- 13 Reset motor limits.
- 14 If a remote control has been supplied you will need to follow the set up procedure outlined in section 11.2.

13.3 Anti-Fall Back Springs (Double Spring) Spring Loaded Operation

General information

The anti-fall back spring is supplied in addition to the standard spring so a spring will be supplied fitted in

13 Anti-fall Back Devices (cont.)

both ends of the axle. The second spring supplied will prevent the curtain from falling in the event of a spring failure.

Installation

If an anti-fall back spring is required it will be supplied inside the pre-assembled shutter box.

If an anti-fall back spring has been supplied fitted in the axle you must follow the standard instructions.

Replacing a spring

In the event of a spring failure the curtain will be lowered to the ground.

If there is only one spring in the axle the curtain can be detached from the axle and the axle assembly removed to enable the spring to be replaced.

If there are two springs in the axle and one of the springs fails the second spring will still be under tension and so care must be taken whilst removing the axle assembly using the procedure below:

If possible lock the spring which is still under tension using a spring retaining pin (supplied with every spring loaded shutter, removed during installation). The curtain can be detached from the axle and the axle assembly removed.

If you are unable to lock the tensioned spring you must hold the axle whilst detaching the curtain then carefully release the axle which will rotate until the tension in the spring has been released. The axle assembly can now be removed.

14 Sloping Bottom Slats

Important information regarding surveying and ordering

1. Must be ordered using the order form

No orders will be accepted for sloping bottom slats unless they are ordered using the SWS UK sloping bottom slat order form. This will ensure you receive the product you require.

2. No bottom slat locks

Unfortunately it is not possible for us to supply a sloping bottom slat with a bottom slat lock fitted.

3. Rubber seal only

All sloping bottom slats will be supplied with the rubber seal used on our SeceuroGlide range. We are unable to supply a sloping bottom slat with a bottom slat reinforcing handle.

4. No woodgrain finish available

We are unable to supply sloping bottom slats in any of our range of woodgrain finishes.

5. Only AEG/X bottom slat

Unless supplied with a SeceuroGlide Compact a sloping bottom slat will always be constructed from an AEG/X bottom slat.

Please note that this differs from the standard bottom slat supplied with SeceuroShield 7700, SeceuroVision 8000 and SeceuroGlide.

A sloping bottom slat for a SeceuroGlide compact will be constructed from an AEG bottom slat.

6. Limited guide rails

When a sloping bottom slat is required on a SeceuroShield 6000 / 7700 or a SeceuroVision 8000 / 9000 the shutter must have UPH250 (90mm) guide rails. Please ensure that your survey has taken this into account.

A SeceuroGlide requiring a sloping bottom slat can be supplied with either H75 or UPH250 guide rails.

A SeceuroGlide Compact will always require UPH140 guide rails.

7. Maximum width

The maximum width for a sloping bottom slat is 5000mm, this is the overall door width including guide rails.

8. Maximum height difference (h)

The maximum height difference (h) the sloping bottom slat can accommodate is 250mm.

When surveying you must ensure that the total height of the sloping bottom slat does not exceed the box end size for the door or you will struggle to load the curtain into the guide rails.

*To obtain the total height of the sloping bottom slat you need to add the standard height of an AEG/X bottom slat (95mm) or the standard height of an AEG bottom slat (60mm) to your height difference (h).

You must also ensure your customer is aware that when the door is fully open the sloping bottom slat will remain in the guide rails reducing the clear height available.

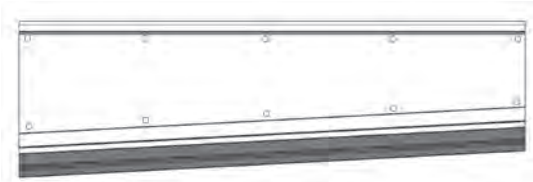
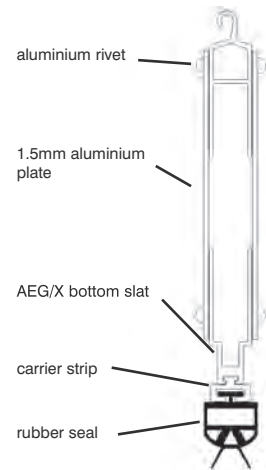

15 Removable Guide Rails

Important information regarding surveying, ordering and installing

1. Must be ordered using the order form

No orders will be accepted for removable guide rails unless they are ordered using the SWS UK removable guide rail order form. This will ensure you receive the products you require.

2. SeceuroVision shutters

Shutters from the SeceuroVision range should be ordered with the locking option in order to maintain security. This will be included by SWS automatically with the surcharge unless your order requests otherwise.

3. How will they be supplied?

Removable (lower) section of the guide rail will be supplied with the locating lug, skid and bolt attached to the guide.

The fixed (top) section of guide rail will be supplied loose with the fixings required to attach it to the end plate. When attaching this section of guide rail ensure that the chamfered end of the guide rail is at the bottom.

The dust caps (bar top recess) will be supplied with the top section of guide rail.

Removable guide rails which meet at either 90° or 180° will be fastened together by SWS. Both guide rails will be supplied with skids but only one locating lug and only one shoot bolt per pair of guide rails.

4. Important installation note

It is imperative that the shutter end plates are securely fixed as the full weight of the shutter will be taken by these fixings.

End plates require at least 2 1/2 inch 10s or 12s twin threaded screws with brown rawl plugs.

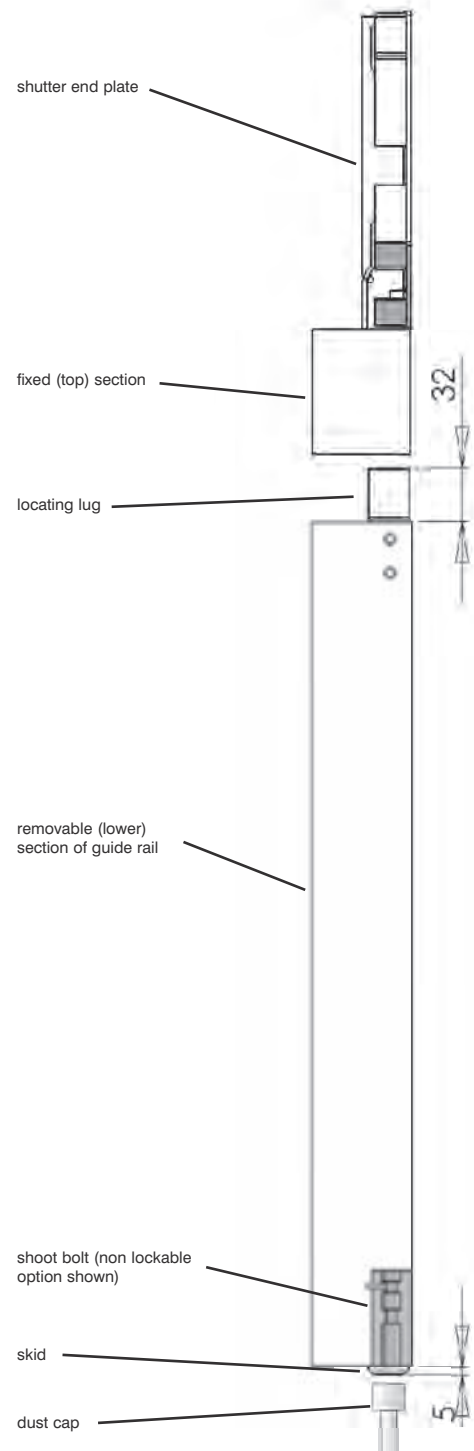
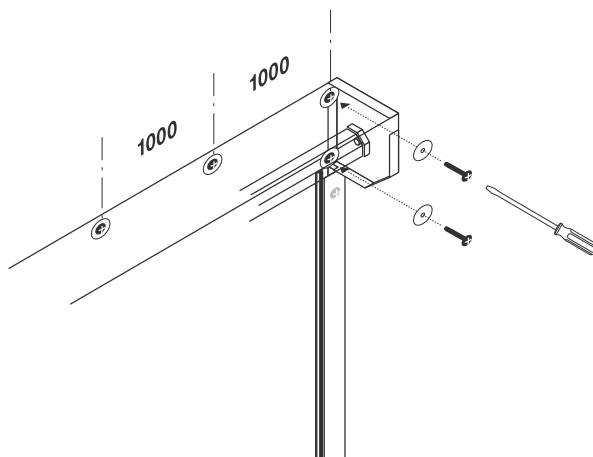

16 technical details

TERMINAL DESCRIPTION			
T1	Live	T11	0 Vdc
T2	Neutral	T12	Stop switch input
T3	Earth	T13	Open switch input
T4	Motor earth	T14	Switch common
T5	Lamp live	T15	Close switch input
T6	Lamp neutral	T16	PEC auto test output
T7	Motor neutral	T17	Switch common
T8	Motor close	T18	PEC input
T9	Motor open	T19	Antenna
T10	+12Vdc	T20	Screen

SWITCH DESCRIPTION			
SW1	Reset	SW4	Close
SW2	DIP switches	SW5	Stop
		SW6	Open

TERMINAL DESCRIPTION	
Supply Voltage	230 VAC / 50hZ
Supply Current	6 Amps (Max)
Transformer power	VA 6VA
Operating temperature (Centigrade)	-10 / +30
Relay	10A @ 230VAC
Triac	1A @ 230VAC
Courtesy light enclosure	40 watts maximum
Short circuit protection	6.3A 20mm HRC fuse
Auxiliary 12VDC	20mA
Photo Electric Cell Input	NPN
Self Check Output	5 VDC
Safe Edge Input	Wireless
Receiver frequency	433.92Mhz
Security (Rolling Code)	Keeloq
IP Rating	44
Dimensions (mm)	H 200 / W 134 / D 68
Connections T1 to T18	Removable

BULB DETAILS
25 watt, round bulb with bayonet fitting supplied

BATTERY DETAILS	
Hand transmitter:	CR2016 (two per transmitter)
Bottom slat transmitter:	CR2016 (four per transmitter)

